

**Installation Instructions for:  
EMS P/N 30-6600**

- 89-94 Nissan 240SX S13 KA24DE**
- 91-94 Nissan Sentra B13 GA16DE**
- 90-94 Nissan Pulsar GTi-R N14 SR20DET**
- 91-93 Nissan NX B13 GA16DE**
- 93-94 Nissan Altima U13 KA24DE**
- 89-95 Nissan Bluebird U13 SR20DET**
- 91-93 Infiniti G20 P10 SR20DE**

**WARNING:**

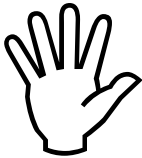

This installation is not for the tuning novice nor the PC illiterate! Use this system with EXTREME caution! The AEM EMS System allows for total flexibility in engine tuning. Misuse of this product can destroy your engine! If you are not well versed in engine dynamics and the tuning of management systems or are not PC literate, please do not attempt the installation. Refer the installation to a AEM trained tuning shop or call 800-423-0046 for technical assistance. You should also visit the AEM EMS Tech Forum at <http://www.aempower.com>

**NOTE: AEM holds no responsibility for any engine damage that results from the misuse of this product!**

**This product is legal in California for racing vehicles only and should never be used on public highways.**

**Note:** Part number 30-6600 supersedes and replaces p/n 30-1600 and 30-1600U

Vehicle	Series I EMS	Series II EMS
1989-1994 Nissan 240SX S13 (KA24DE)	1600/U	6600
1991-1994 Nissan Sentra B13 (GA16DE)	1600/U	6600
1990-1994 Nissan Pulsar GTi-R N14 (SR20DET)	1600/U	6600
1991-1993 Nissan NX B13 (GA16DE)	1600/U	6600
1993-1994 Nissan Altima U13 (KA24DE)	1600/U	6600
1989-1995 Nissan Bluebird U13 (SR20DET)	1600/U	6600
1991-1993 Infiniti G20 P10 (SR20DE)	1600/U	6600

**ADVANCED ENGINE MANAGEMENT INC.**  
2205 126<sup>th</sup> Street Unit A Hawthorne, CA. 90250  
Phone: (310) 484-2322 Fax: (310) 484-0152  
<http://www.aempower.com>  
Instruction Part Number: 10-6600  
© 2010 Advanced Engine Management, Inc.

Thank you for purchasing an AEM Engine Management System.

The AEM Engine Management System (EMS) is the result of extensive development on a wide variety of cars. Each system is engineered for the particular application. The AEM EMS differs from all others in several ways. The EMS is a stand alone system, which completely replaces the factory ECU and features unique Plug and Play Technology, which means that each system is configured especially for your make and model of car without any jumper harnesses. There is no need to modify your factory wiring harness and in most cases your car may be returned to stock in a matter of minutes.

For stock and slightly modified vehicles, the supplied startup calibrations are configured to work with OEM sensors, providing a solid starting point for beginner tuning. For more heavily modified cars, the EMS can be reconfigured to utilize aftermarket sensors and has many spare inputs and outputs allowing the elimination of add-on rev-limiters, boost controllers, nitrous controllers, fuel computers, etc. It also includes a configurable onboard 1MB data logger that can record any 16 EMS parameters at up to 250 samples per second. Every EMS comes with all functions installed and activated; there is no need to purchase options or upgrades to unlock the full potential of your unit.

The installation of the AEM EMS on the supported vehicles uses the stock sensors and actuators. After installing the AEMTuner software, the startup calibration will be saved to the following folder on your PC:

*C:\Program Files\AEM\AEMTuner\Calibrations\Nissan\*

Multiple calibrations may be supplied for each EMS; additional details of the test vehicle used to generate each calibration can be found in the Calibration Notes section for that file.

Please visit the AEM Performance Electronics Forum at <http://www.aempower.com> and register. We always post the most current strategy release, PC Software and startup calibrations online. On the forum, you can find and share many helpful hints/tips to make your EMS perform its best.

### **TUNING NOTES AND WARNING:**

While the supplied startup calibration may be a good starting point and can save considerable time and money, it will not replace the need to tune the EMS for your specific application. AEM startup calibrations are not intended to be driven aggressively before tuning. We strongly recommend that every EMS be tuned by someone who is already familiar with the AEM software and has successfully tuned vehicles using an AEM EMS. Most people make mistakes as part of the learning process; be warned that using your vehicle as a learning platform can damage your engine, your vehicle, and your EMS.

**Read and understand these instructions BEFORE attempting to install this product.**

**1) Install AEMTuner software onto your PC**

The latest version of the AEMTuner software can be downloaded from the AEMTuner section of the AEM Performance Electronics forums. Series 2 units are not supported by the older AEMPro tuning software.

**2) Change Cam/Crank Angle Sensor: AEM trigger disc MUST be used**

On Nissans, discrepancies have been observed in the OEM cam/crank angle signals between model years and/or trim levels. To avoid confusion the Series 2 EMS does not support the OEM Nissan trigger pattern. A replacement trigger disc is now included with every Nissan EMS and must be installed before attempting to start the engine. An AEM trigger disc is supplied with each 30-6600 EMS which fits KA, GA, and SR sensors. Please consult the following instructions supplement, which will be installed to the C:\Program Files\AEM\AEMTuner\Instructions folder:

'10-6600-C for EMS - 30-66XX supplement- CAS trigger install KA, GA, and SR engines.PDF'

**3) Remove the Stock Engine Control Unit**

- a) Access the stock Engine Control Unit (ECU). The location of the ECU on the Nissan 240SX vehicles is behind the kick-panel on the passenger side of the vehicle. All other Nissan/Infiniti control units are located on the floor behind the center console accessed from the passenger side.
- b) Carefully disconnect the wiring harness from the ECU. Avoid excessive stress or pulling on the wires, as this may damage the wiring harness. Some factory ECUs use a bolt to retain the factory connectors, and it must be removed before the harness can be disconnected. There may be more than one connector, and they must all be removed without damage to work properly with the AEM ECU. Do not cut any of the wires in the factory wiring harness to remove them.
- c) Remove the fasteners securing the ECU to the car body, and set them aside. Do not destroy or discard the factory ECU, as it can be reinstalled easily for street use and troubleshooting.

**4) Install the AEM Engine Management System**

- a) Plug the factory wiring harness into the AEM EMS and position it so the wires are not pulled tight or stressed in any manner. Secure the EMS with the provided Velcro fasteners.
- b) Plug the comms cable into the EMS and into your PC.
- c) Turn the ignition on, but do not attempt to start the engine.
- d) At the time these instructions were written, new EMS units do not require USB drivers to be installed to the PC.
- e) With the AEMTuner software open, select **ECU>>Upload Calibration** to upload the startup calibration file (.cal) that most closely matches the vehicle's configuration to be tuned. Check the Notes section of the calibration for more info about the vehicle it was configured for. These files can be found in the following folder:  
*C:\Program Files\AEM\AEMTuner\Calibrations\Nissan\*
- f) Set the throttle range: Select Wizards>>Set Throttle Range and follow the on-screen instructions. When finished, check that the 'Throttle' channel never indicates less than 0.2% or greater than 99.0%, this is considered a sensor error and may cause some functions including idle feedback and acceleration fuel to operate incorrectly.

## 5) Wiring accessories to the EMS:

Please follow this suggested wiring diagram when adding accessories such as UEGO gauges, MAP sensors, IAT sensors, or switches for use with the EMS. Note that wire polarity is not important for the Air Temperature sensor.

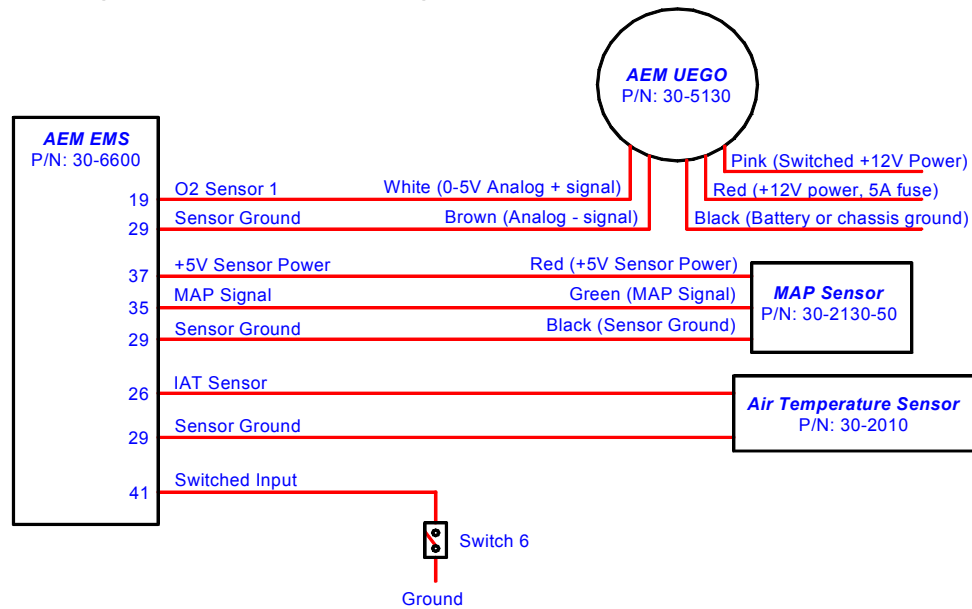

## 6) Ready to begin tuning the vehicle.

- Before starting the engine, verify that the fuel pump runs for a couple of seconds when the key is turned on and there is sufficient pressure at the fuel rail.  
If a MAP sensor is installed, check that the Engine Load indicates something near atmospheric pressure (approximately 101kPa or 0 PSI at sea level) with the key on and engine off. Press the throttle and verify that the 'Throttle' channel responds but the Engine Load channel continues to measure atmospheric pressure correctly.
- Start the engine and make whatever adjustments may be needed to sustain a safe and reasonably smooth idle. Verify the ignition timing: Select **Wizards>>Ignition Timing Sync** from the pull-down menu. Click the 'Lock Ignition Timing' checkbox and set the timing to a safe and convenient value (for instance, 10 degrees BTDC). Use a timing light and compare the physical timing numbers to the timing value you selected. Use the *Sync Adjustment Increase/Decrease* buttons to make the physical reading match the timing number you selected.

Crankshaft timing marks are not labeled for some vehicles. Consult the factory service manual for more information. The diagram below shows marks for the 240SX:

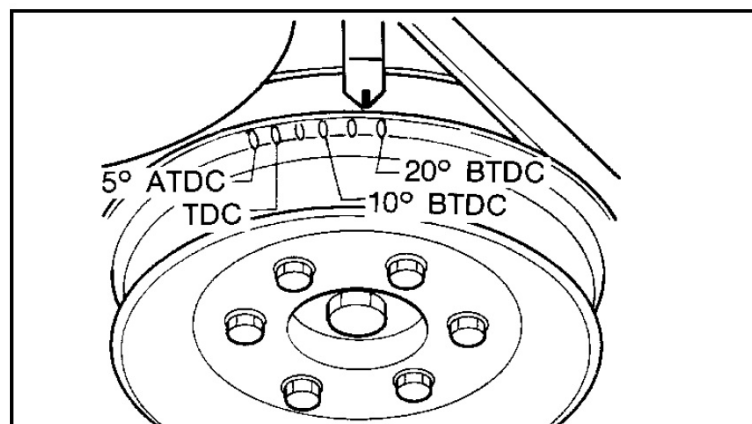

- c) Note: This calibration needs to be properly tuned before driving the vehicle. It is intended for racing vehicles and may not operate smoothly at idle or part-throttle.  
**NEVER TUNE THE VEHICLE WHILE DRIVING**

## **7) Troubleshooting an engine that will not start**

- a) Double-check all the basics first... engines need air, fuel, compression, and a correctly-timed spark event. If any of these are lacking, we suggest checking simple things first. Depending on the symptoms, it may be best to inspect fuses, sufficient battery voltage, properly mated wiring connectors, spark using a timing light or by removing the spark plug, wiring continuity tests, measure ECU pinout voltages, replace recently-added or untested components with known-good spares. Check that all EMS sensor inputs measure realistic temperature and/or pressure values.
- b) If the EMS is not firing the coils or injectors at all, open the Start tab and look for the 'Stat Sync'd' channel to turn ON when cranking. This indicates that the EMS has detected the expected cam and crank signals; if Stat Sync'd does not turn on, monitor the Crank Tooth Period and T2PER channels which indicate the time between pulses on the Crank and T2 (Cam) signals. Both of these channels should respond when the engine is cranking, if either signal is not being detected or measuring an incorrect number of pulses per engine cycle the EMS will not fire the coils or injectors.
- c) With the engine not running, if the Engine Load changes when the throttle is pressed this usually indicates that there is a problem with the MAP sensor wiring or software calibration (when the EMS detects that the MAP Volts are above or below the min/max limits it will run in a failsafe mode using the TPS-to-Load table to generate an artificial Engine Load signal using the Throttle input). This may allow the engine to sputter or start but not continue running properly.

# Application Notes for EMS P/N 30-6600

## KA24DE, GA16DE, SR20DE, SR20DET

Make:	Nissan/Infiniti
Model:	240SX, Sentra, Pulsar GTiR, NX, Altima, Bluebird, G20
Years Covered:	1989-1995
Engine Displacement:	1.6L, 2.0L, 2.4L
Engine Configuration:	Inline 4
Firing Order:	1-3-4-2
N/A, S/C or T/C:	N/A, T/C
Load Sensor Type:	0-5V MAF
Number of Coils:	1 (Distributor)
Ignition driver type:	0-5V Falling Edge trigger
Number of Injectors:	4 (P&H drivers: Inj 1-4)
Factory Injectors:	185cc - 444cc
Factory Inj Resistors:	Pulsar GTiR only
Injection Mode:	Sequential
Knock Sensors used:	1
Lambda Sensors used:	1
Idle Motor Type:	Duty-controlled solenoid
Main Relay Control:	Yes (not user programmable)
Crank Pickup Type:	Optical
Crank Teeth/Cycle:	24 (AEM trigger disc)
Cam Pickup Type:	Optical
** Cam Teeth/Cycle:	1 (AEM trigger disc)
Transmissions Offered:	Manual/Automatic
Trans Supported:	Manual only
Drive Options:	FWD, RWD, AWD
Supplied Connectors:	N/A
AEM extension/patch harness	30-2995

Spare Injector Drivers:	Inj 5, Pin 23
Spare Injector Drivers:	Inj 6, Pin 105
Spare Injector Drivers:	Inj 7, Pin 14
Spare Injector Drivers:	Inj 8, Pin 114
Spare Coil Drivers:	Coil 2, Pin 7
Spare Coil Drivers:	Coil 3, Pin 5
Spare Coil Drivers:	Coil 4, Pin 25
Boost Solenoid:	PW2, Pin 111
EGT #1 Location:	Pin 8
EGT #2 Location:	Pin 15
EGT #3 Location:	Pin 44
EGT #4 Location:	Pin 115
Spare 0-5V Input:	MAP, Pin 35
Spare 0-5V Input:	ADCR11, Pin 33
Spare Low Side Driver:	LS2, Pin 45
Spare Low Side Driver:	LS4, Pin 102
Spare Low Side Driver:	LS5, Pin 10
Spare Low Side Driver:	LS9, Pin 106
Check Engine Light:	LS10, Pin 24
Spare High Side Driver:	HS1, Pin 28
Spare Switch Input*:	Switch 2, Pin 43
A/C Switch Input*:	Switch 6, Pin 41

### Wire View of AEM EMS

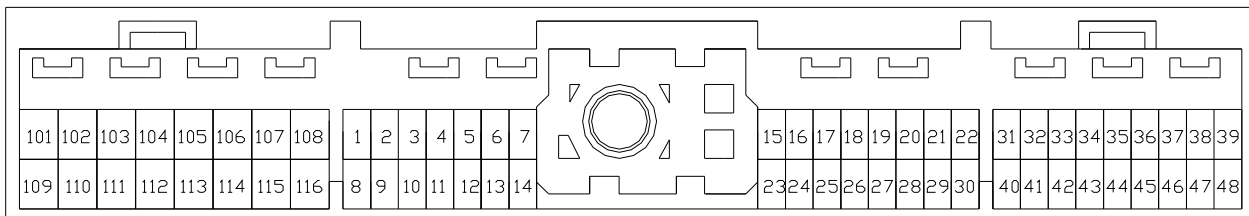

**WARNING:**

\*All switch input pins must connect to ground; the switch should not provide 12V power to the EMS because that will not be detected as on or off.

### **Engine Wiring Harnesses, 'swapped' engine installations**

Many Nissan wiring harnesses have been found to contain significant differences between model years and/or trim levels. Likely differences include: Crank signal, Cam signal, Ignition switch wiring (the Ignition switch input controls the Main Relay output), injector and coil destinations. Official documentation for these vehicles was not offered in English, so it would be very wise to double-check the pinout destinations for these circuits. This is especially true if the vehicle contains a 'swapped' engine or if the wiring harness has been cut, spliced, soldered, tapped or modified in any manner. It is the user's responsibility to check that the wiring on the vehicle matches the pinout chart below. AEM will not be held responsible for loss or damage that can occur if the EMS is installed in a vehicle in which the wiring harness does not match the AEM-supplied pinout chart!

The function of several pins have been changed from the original 30-1600 EMS, please see the pinout chart for more info.

### **Primary Load Sensor, EMS Fuel Strategy**

The factory MAF (mass air flow) sensor(s) can be removed to help decrease intake air restriction; the EMS can be configured to use a MAP sensor to determine engine load. It is recommended to use a 3.5 bar MAP sensor or higher (P/N 30-2130-50).

The factory Mass Air Flow sensor can be used as the primary load input for the AEM EMS if desired. Please check the Notes section of each calibration for more info about the vehicle setup and fuel strategy that calibration was configured to use.

### **EMS Fuel Map, Boost Fuel Trim Table**

Some of the 30-6600 maps provided utilize the "*Boost Fuel Trim Table*" to provide a 1:1 fuel compensation above and below atmospheric pressure. In the startup calibration, the "*Boost Fuel Trim Table*" is configured to provide twice as much fuel when the manifold pressure is twice as high and half the fuel when the manifold pressure is half as high; this should help simplify the tuning process for different vacuum and boost levels. Notice the values in the main "*Fuel Map*" do not change above 100 kPa (0 psi boost), the fuel correction is being made by the "*Boost Fuel Trim Table*."

Note: the "*Boost Fuel Trim Table*" must be adjusted if a different MAP sensor is installed or if the Load breakpoints are adjusted. The Boost Fuel Trim value should be set to -90 at 10kPa, 0 at 100 kPa, +100 at 200 kPa, +200 at 300 kPa, etc...

### **Peak and Hold Injector Drivers**

Injectors 1-4 include Peak (4 amps) and Hold (1 amp) injector drivers. These drivers may be used with peak and hold or saturated type injectors. Some factory wiring harnesses may contain a resistor pack to prevent excessive current when using low-impedance injectors with the stock ECU. With the 30-6600 installed, users can elect to remove and bypass the OEM resistor pack (if one was installed) for more precise control of low-impedance injectors.

Please note that the injector response time will be different with and without the factory injector resistor pack. If the OEM resistor pack has been removed and bypassed, please use the correct battery offset wizard for your injectors. Most battery offset wizards will specify <P&H DRIVER> if they are intended for use without a resistor pack.

# Connection Diagram for EMS P/N 30-6600

PnP	Means the Plug and Play system comes with this configured for proper operation of this device. Is still available for reassignment by the end user.
Available	Means the function is not currently allocated and is available for use
Dedicated	Means the location is fixed and cant be changed

Pin	1989-1994 Nissan 240SX S14 KA24DE 1991-1994 Nissan Sentra B13 GA16DE 1990-1994 Nissan Pulsar GTi-R N14 SR20DET 1991-1993 Nissan NX B13 GA16DE 1993-1994 Nissan Altima U13 KA24DE 1989-1995 Nissan Bluebird U13 SR20DET 1991-1993 Infiniti G20 P10 SR20DE	AEM EMS 30-6600	I/O	Notes
1	Ignition Signal	Coil 1	Output	PnP for Coil 1, 0-5V falling edge trigger
2	Tachometer Signal	Low Side 7	Output	PnP for Tachometer
3	Ignition Check	---	---	Not Used
4	ECCS Relay control, Ignition Relay control	Main Relay	Output	Dedicated, EMS activates relay with switched GND
5	---	Coil 3	Output	Available Coil 3, 0-5V falling edge trigger
6	ECCS Ground	Power Ground	Input	Dedicated
7	Data Link Connector	Coil 2	Output	Available Coil 2, 0-5V falling edge trigger
8	EGR Sensor (Except 89-90 Non CA 240SX and SR20DET)	EGT 1	Input	Available, jumper set for 0-5V Input
9	Cooling Fan Relay	Low Side 3 + Low Side 12	Output	PnP for Cooling Fan, can be activated by LS3 or LS12 output
10	Cooling Fan High Speed (A/T 2.0L only)	Low Side 5	Output	Available, Switched Ground, 1.5A max
11	Air Conditioner Relay	Low Side 6	Output	Available, Switched Ground, 1.5A max
12	Swirl Control Valve (89-90 240SX Only)/VTC Solenoid (1.6L only)	CAN1H	Input	Dedicated. CAN high side
13	ECCS Ground	Power Ground	Input	Dedicated
14	Diagnostics Clock	Injector 7	Output	Available, Switched Ground, 1.5A Max

## Wire View of AEM EMS

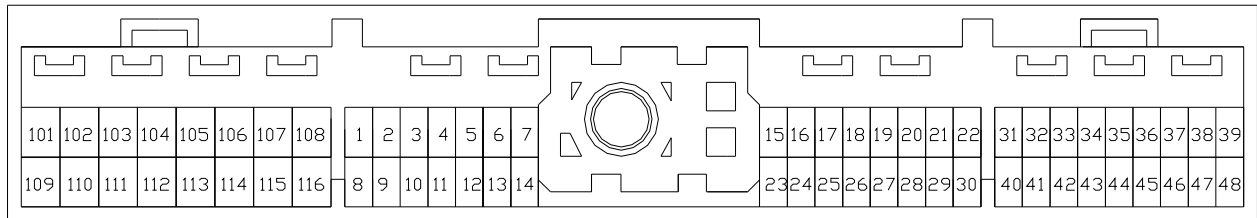

# Connection Diagram for EMS P/N 30-6600

Pin	1989-1994 Nissan 240SX S14 KA24DE 1991-1994 Nissan Sentra B13 GA16DE 1990-1994 Nissan Pulsar GTi-R N14 SR20DET 1991-1993 Nissan NX B13 GA16DE 1993-1994 Nissan Altima U13 KA24DE 1989-1995 Nissan Bluebird U13 SR20DET 1991-1993 Infiniti G20 P10 SR20DE	AEM EMS 30-6600	I/O	Notes
15	Data Link Connector	EGT 2	Input	Available, jumper set for 0-5V input
16	Mass Air Flow Sensor	MAF	Input	PnP for MAF Sensor
17	Mass Air Flow Ground	Power Ground	Input	Dedicated
18	Engine Coolant Temperature Sensor	Coolant	Input	PnP for Coolant Temp Sensor
19	Oxygen Sensor	O2 #1	Input	Dedicated, 0-5V input signal
20	Throttle Position Sensor	TPS	Input	PnP for Throttle Position Sensor
21	Sensor Ground	Sensor Ground	Output	Dedicated
22	Crankshaft Reference Signal	Cam (T2)	Input	Dedicated, must use AEM replacement trigger disc. Connects to pin 30
23	Diagnostics check (SR20 only)	Injector 5	Output	Available, Switched Ground, 1.5A Max
24	Malfunction Indicator Light	Low Side 10	Output	Available, Switched Ground, 1.5A Max
25	Swirl Control Valve (91-94 240SX only)	Coil 4	Output	Available Coil 4, 0-5V falling edge trigger
26	Air Temp Sensor (Late 89 and all 90 240SX)	AIT	Input	Available, AIT Sensor Input
27	Knock Sensor (Except 89-90 240SX & 1.6L)	Knock 1	Input	PnP for Knock Sensor
28	Throttle Signal Output (A/T only)	High Side 1	Output	Available, +12V, 1.5A Max
29	Sensor Ground	Sensor Ground	Output	Dedicated
30	Crankshaft Reference Signal	Cam (T2)	Input	Dedicated, must use AEM replacement trigger disc. Connects to pin 22

## Wire View of AEM EMS

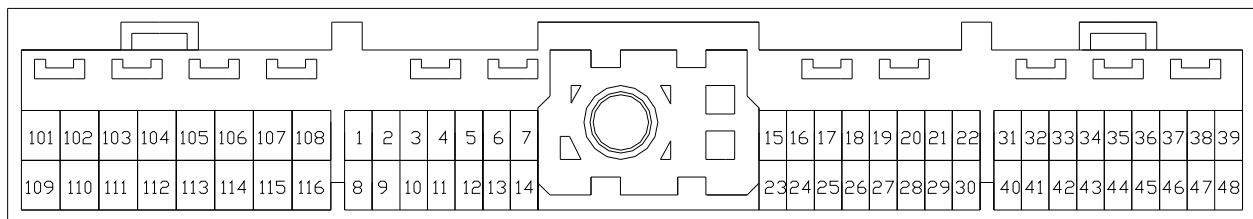

# Connection Diagram for EMS P/N 30-6600

Pin	1989-1994 Nissan 240SX S14 KA24DE 1991-1994 Nissan Sentra B13 GA16DE 1990-1994 Nissan Pulsar GTi-R N14 SR20DET 1991-1993 Nissan NX B13 GA16DE 1993-1994 Nissan Altima U13 KA24DE 1989-1995 Nissan Bluebird U13 SR20DET 1991-1993 Infiniti G20 P10 SR20DE	AEM EMS 30-6600	I/O	Notes
31	Crankshaft Position Sensor Signal	Crank Signal	Input	Dedicated, must use AEM replacement trigger disc. Connects to pin 40
32	Vehicle Speed	Vehicle Speed	Input	PnP for Vehicle Speed Sensor
33	Idle Sw (89-90 240SX)/5 <sup>th</sup> Pos Sw (91-94 240SX)	ADCR11	Input	Available, 0-5 Volt Input
34	Start Signal	+12V Switched	Input	Dedicated
35	Neutral Position Switch	MAP	Input	Available, Manifold Pressure
36	Ignition Switch	Ignition Switch	Input	Dedicated, +12V activates Main Relay circuit
37	Throttle Position Sensor Power	+5V Sensor	Output	Dedicated
38	Power Supply for ECM	+12V Switched	Input	Dedicated, +12V power when ECCS Relay is on
39	ECCS Ground	Power Ground	Input	Dedicated
40	Crankshaft Position Signal	Crank Signal	Input	Dedicated, must use AEM replacement trigger disc. Connects to pin 31
41	Air Conditioner Switch	Switch 6	Input	PnP for A/C Switch
42	4 <sup>th</sup> Position Switch (91-94 240SX only)	CAN1L	Input	Dedicated, CAN low side
43	Power Steering Oil Pressure Switch	Switch 2	Input	Available, Switched Input
44	Idle Switch Positive Side (89-90 240SX); Rear window defogger (91-94 240SX)	EGT 3	Input	Available, jumper set for 0-5V Input
45	Air Conditioner FICD (Except 2.0L); Position Sw (89-90 240SX)	Low Side 2	Output	Available, Switched Ground, 1.5A Max
46	Back-up Power Supply	Permanent +12V	Input	Dedicated, used to store internal log
47	Power Supply for ECM	+12V Switched	Input	Dedicated, +12V power when ECCS Relay is on
48	ECCS Ground	Power Ground	Input	Dedicated
101	Injector 1	Injector 1	Output	PnP for Injector 1 (Peak & Hold 4A/1A driver)
102	Pulse Secondary Air Inj (240SX & 91-93 2.0L only)	Low Side 4	Output	Available, Switched Ground, 1.5A max
103	Injector 3	Injector 3	Output	PnP for Injector 3 (Peak & Hold 4A/1A driver)
104	Fuel Pump Relay control	Low Side 11	Output	PnP for Fuel Pump
105	EGR Control Solenoid Valve	Injector 6	Output	Available, Switched Ground, 1.5A max
106	Pressure Regulator Control Sol (89-90 240SX only)	Low Side 9	Output	PnP for Fuel Pump
107	ECCS Ground	Power Ground	Input	Dedicated
108	ECCS Ground	Power Ground	Input	Dedicated
109	Back-Up Power Supply	Permanent +12V	Input	Dedicated, used to store internal log
110	Injector 2	Injector 2	Output	PnP for Injector 2 (Peak & Hold 4A/1A driver)
111	O2 Sensor Heater (91-94 2.0L & 94 1.6L only)	PW 2	Output	Available, Switched Ground, 1.5 max
112	Injector 4	Injector 4	Output	PnP for Injector 4 (Peak & Hold 4A/1A driver)
113	Idle Auxiliary Air Control Valve	PW 1	Output	PnP for Idle Air Control
114	---	Injector 8	Output	Available, Switched Ground, 1.5A max
115	---	EGT 4	Input	Available, jumper set for 0-5V Input
116	ECCS Ground	Power Ground	Input	Dedicated

## Wire View of AEM EMS

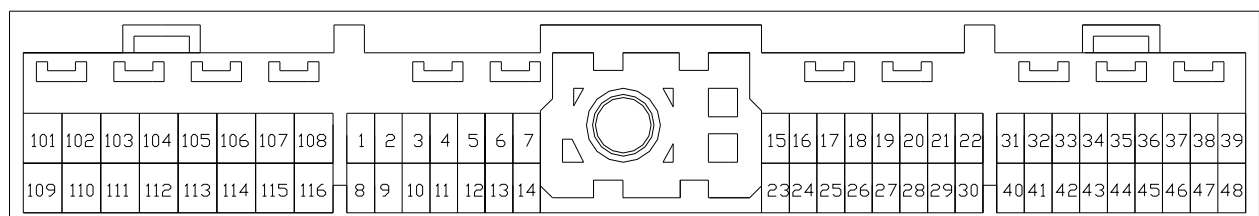

**30-1600 (Series 1) vs 30-6600 (Series 2) EMS differences:**

The EMS functions assigned to certain pins have been changed and no longer match the 30-1600 EMS. Unless otherwise noted, the following pins and functions will need to be manually reconfigured after using AEMTuner to convert a V1.19 30-1600, Series 1 EMS calibration for use with the 30-6600 Series 2 hardware.

Pin	Vehicle harness destination	30-1600 function	30-6600 function	Notes
12	CAN	Low Side 8	CAN1H	LS8 not available
15	TX Data	Injector 8	EGT 2	Injector 8 moved to pin 114
42	CAN	Switch 1	CAN1L	Switch 1 not available
114	---	EGT 2	Injector 8	EGT 2 moved to pin 15

## **AEM Electronics Warranty**

Advanced Engine Management Inc. warrants to the consumer that all AEM Electronics products will be free from defects in material and workmanship for a period of twelve months from date of the original purchase. Products that fail within this 12-month warranty period will be repaired or replaced when determined by AEM that the product failed due to defects in material or workmanship. This warranty is limited to the repair or replacement of the AEM part. In no event shall this warranty exceed the original purchase price of the AEM part nor shall AEM be responsible for special, incidental or consequential damages or cost incurred due to the failure of this product. Warranty claims to AEM must be transportation prepaid and accompanied with dated proof of purchase. This warranty applies only to the original purchaser of product and is non-transferable. All implied warranties shall be limited in duration to the said 12-month warranty period. Improper use or installation, accident, abuse, unauthorized repairs or alterations voids this warranty. AEM disclaims any liability for consequential damages due to breach of any written or implied warranty on all products manufactured by AEM. Warranty returns will only be accepted by AEM when accompanied by a valid Return Merchandise Authorization (RMA) number. Product must be received by AEM within 30 days of the date the RMA is issued.

Please note that before AEM can issue an RMA for any electronic product, it is first necessary for the installer or end user to contact the tech line at 1-800-423-0046 to discuss the problem. Most issues can be resolved over the phone. Under no circumstances should a system be returned or a RMA requested before the above process transpires.

AEM will not be responsible for electronic products that are installed incorrectly, installed in a non approved application, misused, or tampered with.

Any AEM electronics product can be returned for repair if it is out of the warranty period. There is a minimum charge of \$75.00 for inspection and diagnosis of AEM electronic parts. Parts used in the repair of AEM electronic components will be extra. AEM will provide an estimate of repairs and receive written or electronic authorization before repairs are made to the product.