

AIR INLET TEMPERATURE (AIT) SENSOR

PART NUMBER 30-2010

FEATURES

- Design for Manufacturability
- Cost Effective
- Robust Design
- Few Components & Assembly Processes
- Thermistor Technology
- 100% Calibration Certified

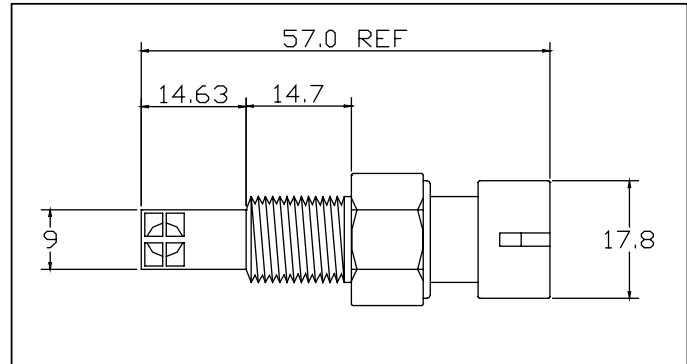

Thermal & Electrical Properties

Typical Voltage Supply	5Vdc
Operating Temperature	-40°C to 135°C
Resistive Range(Ω)	See Table
Dissipation Constant	‡ N/A
Thermal Time Constant	‡‡ < 15 seconds
Accuracy	See Table

Mechanical Characteristics

Sensor Body Material	Brass Housing
Connector	PBT 30% GF
Basket	PBT 40% GF
Hex Size	18.90mm (3/4")
Thread Size	3/8" - 18 NPT
Sealing Pressure	200 kPa
Installation Torque	20 N-m, dynamic
Overall Weight	33.3g

Thermal Time Constant ‡‡

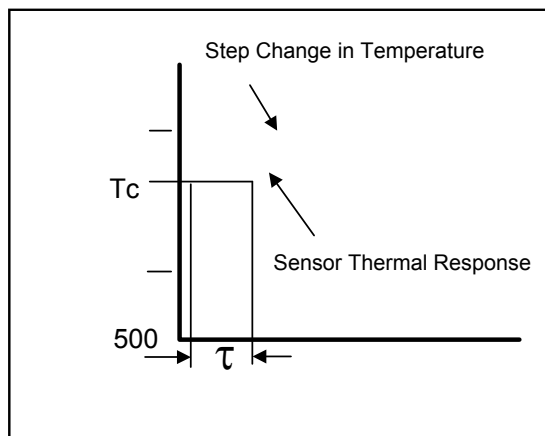

Circuit Schematic

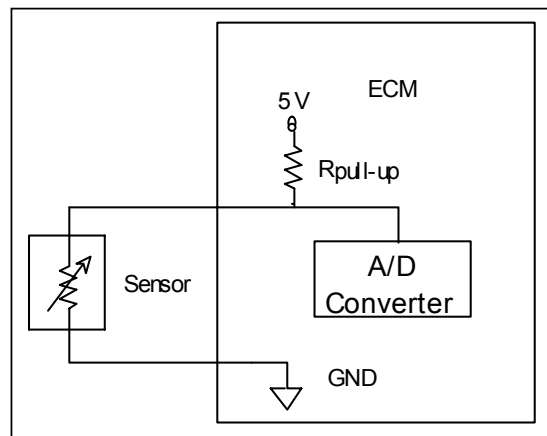

‡ The ratio, at a specified ambient temperature, of the change in the power dissipation of the sensor to the resultant temperature change of the thermistor. Test medium: silicone oil.

‡‡ The time required for the sensor to achieve 63.2% of its steady state value when subjected to a step change in ambient temperature [$T_c = (T_f - T_i) * 63.2\% + T_i$]. Test medium: silicone oil.