



Kit Part Number: 25-131

**Mitsubishi Lancer Evolution 8 2003-2005
Mitsubishi Lancer Evolution 9 2006**

© 2006, Advanced Engine Management, Inc. AEM is a registered trademark of Advanced Engine Management, Inc. All rights reserved.



Advanced Engine Management Inc.
2205 126th Street, Unit A
Hawthorne, CA 90280
Phone: 310.484.2322
<http://www.aempower.com>

THE INFORMATION CONTAINED IN THIS DRAWING IS THE SOLE PROPERTY OF ADVANCED ENGINE MANAGEMENT, INC. ANY REPRODUCTION IN PART OR WHOLE WITHOUT THE WRITTEN PERMISSION OF ADVANCED ENGINE MANAGEMENT, INC. IS PROHIBITED.

Kit Contents

Part Number	Description	Qty
2-5031	Fuel Rail	1
10-922S	AEM Decal	2
1465A188	Injector O-Ring	4
1-121	Pipe Plug	1

Kit Contents

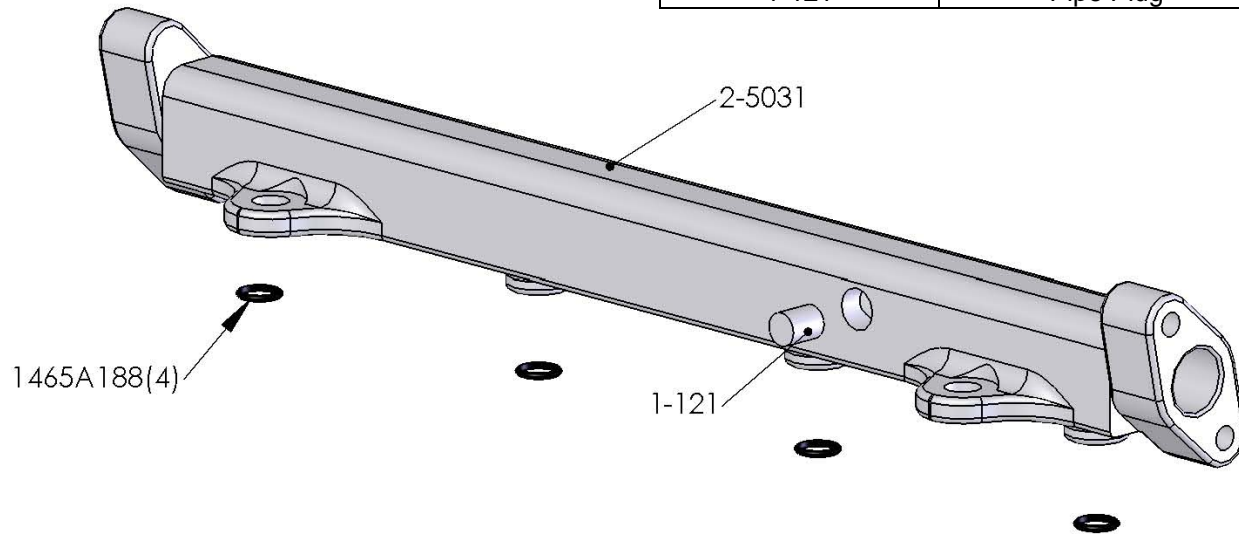

! WARNING

Read and understand these instructions **BEFORE** attempting to install this product.

- **Do not smoke while working on the fuel system.**
 - **Keep open flames or sparks away from your work area.**
 - **Be sure to relieve fuel pressure before beginning fuel rail installation.**
1. **Preparing Vehicle**
 - a) Make sure vehicle is parked on a level surface.
 - b) Set parking brake.
 - c) If engine has run in the past two hours let it cool down.
 2. **Removal of Stock Fuel Rail**
 - a) Loosen the two (2) 6mm bolts securing the fuel supply line to the driver's side end of the stock fuel rail.
 - b) Carefully remove the stock fuel supply line from the rail. Make sure to avoid damaging the factory o ring, as it will be reused later.
 - c) Loosen the two (2) 6mm bolts securing the fuel pressure regulator to the passenger's side of the stock fuel rail.
 - d) Carefully remove the stock fuel pressure regulator from the rail. Make sure to avoid damaging the O ring as it will be reused later.
 - e) Remove the two (2) 8mm bolts securing the stock fuel rail to the intake manifold.
 - f) Remove the stock fuel rail and injectors.
 3. **Preparation for Installation of AEM Fuel Rail**
 - a) Remove the injectors from the stock fuel rail
 - b) Remove the stock o rings from the fuel injectors.
 - c) Clean the injector o ring area, and install the included injector o rings.
 - d) Lubricate the injector o rings, and the injector bores of the AEM fuel rail, and install the injectors, with the injector plugs facing the front of the rail (the side with the AEM logo)
 - e) Install the included 1/8" NTP plug in the front side treaded hole in the AEM fuel rail.

4. Installation of the AEM Fuel Rail.

- a) Install the AEM fuel rail by placing the injectors into the injector seals in the intake manifold with the AEM logo on the fuel rail facing upward.
- b) Secure the fuel rail to the intake manifold using the factory 8mm bolts.
- c) Lubricate the fuel pressure regulator o ring, and the passengers side fuel rail bore, and carefully install the regulator into the fuel rail.
- d) Secure the regulator using the original 6mm bolts.
- e) Lubricate the fuel supply line o ring, and the drivers side fuel rail bore, and carefully insert the fuel supply line into the driver side of the fuel rail.
- f) Secure the fuel supply line using the factory 6mm bolts.

5. Final Checks

- a) **Before** starting the engine, activate the ignition key to the run position 2 or 3 times to prime the fuel system. Check for leaks at the injectors, and ends of the fuel rail.
- b) Providing there are NO leaks start the engine and re-check for leaks.
- c) Correct any leaks before driving the vehicle.

For technical inquiries
e-mail us at tech@aempower.com
or
call us at
310.484.2322 Option #3