



TRU-TIME CAM GEARS

1993 – 1997 Dodge Neon
Part number 23 – 850 series



WARNING:

This installation is not for the mechanically challenged! If you are not mechanically inclined or do not understand the procedure please do not attempt the installation. Refer the installation to a reputable mechanic. It is highly recommended to purchase the factory service manual to use as a guide along with these instruction sheets.

Legal in California **ONLY** for racing vehicles, which may never be used upon a highway.

ADVANCED ENGINE MANAGEMENT INC.

2205 126th. St. Unit A Hawthorne CA 90250

Phone: (310) 484-2322 Fax: (310) 484-0152

[Http://www.aempower.com](http://www.aempower.com)

Instruction Part Number: 10-254

© 1998 Advanced Engine Management, Inc.

You have just purchased the **BEST** adjustable cam sprockets available. These **AEM Inc.** adjustable cam sprockets are CNC machined from billet aluminum and then laser etched with cam timing marks for adjustment up to $\pm 10^\circ$ at the cam or $\pm 20^\circ$ at the crankshaft. Using the vernier scale on the sprocket hub helps to perform cam timing changes quickly and accurately. The inner hub is anodized for lasting beauty and resistance to corrosion. The out gear sector is hard anodized for resistance to wear.

We have found that there are significant power gains to be made by adjusting the cam timing even with stock cams and compression. Adjustable cam sprockets are usually required in applications where an aftermarket or reground performance cams are installed or the cylinder head has been milled 0.005" or more. The use of these cam sprockets allows the extraction of maximum power from your engine. We have recorded gains of up to 10~15 horsepower due to cam timing tuning using adjustable cam sprockets.

When aftermarket or reground cams are installed, the original manufacturer's cam timing specifications are no longer accurate. These adjustable cam sprockets allow you to make necessary adjustments to cam timing to maximize the performance of your engine. This is accomplished by "degreeing in" the optimum cam timing for a particular engine set up.

The adjustable cam sprocket is especially effective when used with heads that have been milled. The adjustability of the sprocket allows the accommodation of the changes in cam timing due to the variation of timing belt length from the bottom sprocket to the top sprocket when the head is milled. If the head has been milled 0.005" or greater the relationship between the head and the block is altered by moving the head closer to the crankshaft resulting in retarded cam timing.

It must be emphasized that the preceding descriptions are generalizations and any adjustments made must be done with a conservative approach and on a dynamometer or on a racetrack. We do not condone any illegal activity on the street.

Read and understand these instructions BEFORE attempting to install this product.

- 1) It is important that the installer familiarize themselves with the procedures before starting the installation. This procedure requires some very specialized tools, which cannot be substituted with any substandard equipment. It is important to have a factory service manual available for reference while undertaking this installation. This procedure is best accomplished using a lift. If a suitable lift is not available, for safety reasons, use appropriately rated jackstands.
- 2) Disconnect the negative battery cable.
- 3) With the front of the vehicle raised, drain the coolant from the radiator. The drain plug for the radiator is located just to the right of the lower radiator hose (when viewed from underneath). Make sure to collect all the coolant in a clean container so that it can be re-used.
 - a) Disconnect the upper radiator hose and remove from the area of work.
 - b) Disconnect the coolant line located to the right of the radiator hose and position it away from the area of work.
- 4) Remove all the accessory drive belts. *See Timing Belt System Diagram*
 - a) Alternator drive belt
 - b) Air conditioning and power steering pump belt.
- 5) Remove the right front wheel.
 - a) Remove the right inner splash shield and the right engine-mount bolt access plug. *See Figure 1*
- 6) Position a jack underneath engine for support.
 - a) Disconnect and remove the purge solenoid valve from the right front engine mount. Mark the vacuum lines before you remove the valve so that they can be returned to their original positions.
 - b) Remove the two engine mount to frame rail bolts on either side of the engine mount. *See Figure 2*
 - c) From the wheel well loosen the engine mount through bolt.
 - d) Jack the engine up until the engine mount clears the frame rail and then remove the engine mount through bolt.
- 7) Remove the power steering pump. This will allow you to move the power steering hoses from the front of the engine. Try not to disconnect any hoses to prevent leakage. If any hoses are disconnected, any o-rings at the banjo connections at the top of the pump will need to be replaced. You will also need to prevent any contamination of the power steering pump. *See Figures 3&4*
 - a) Remove two bolts at the back of the rear bracket and loosen one bolt on the front bracket.
 - b) Lift the pump up to clear the engine and lay the pump on the cam cover.
- 8) Remove the front bracket plate. *See Figure 7*
 - a) Remove the bolts on the front bracket plate and lift the bracket out of the engine compartment. The bolts for the front bracket plate are quite long so lift the engine as needed to obtain the necessary clearance but be careful that other engine components are not damaged in any way resulting from jacking the motor too high.
- 9) Remove the front crankshaft pulley. *See Figure 5*
 - a) The stock pulley is an assembled component. In most cases a weld gap is evident on the area where the Poly-V alternator belt rides. This is the normal appearance of the pulley but it does not represent a timing mark of any kind. There are no timing indicators on the front crank pulley.
 - i) Loosen and remove the center bolt of the pulley. The bolt is installed from the factory using thread-locking compound on the pulley center bolt.
 - b) The pulley does not have any timing marks on it nor is it keyed to the crankshaft. The pulley is pressed on and requires a three-jaw puller to remove it from the crankshaft.
 - i) **WARNING**
 - (1) Do not use pry bars against the rear of the pulley or against the front cover of the engine. Damage to the pulley or the front engine cover could result.
 - c) Install the puller as depicted in the diagram but ensure that the center bolt of the puller remains straight and centered on the pulley.
 - d) Once the pulley has been removed you can take the front engine cover off by removing the two lower attaching bolts and the top center bolt.
- 10) Remove the timing gear cover *See Figure 7*
 - a) Remove the upper access panel. This is held in place with a single bolt.

- b) Remove two bolts at the bottom of the timing gear cover
 - c) Move the cover away from the front of the engine and lift upward and away from the area of work.
- 11) Check the cam timing. Align all the timing marks before you remove the belt. The diagram shows the position of all the pulleys when the marks are properly aligned. *See Figures 8 & 9*
- a) Loosen the cam gear pulley bolts but do not remove them at this time.
 - b) The factory manual suggests removing the tensioner and resetting it using a bench vise prior to installation.
 - i) You can bypass the tensioner resetting procedure by inserting a $\frac{3}{64}$ (0.0468") lock pin into the top of the tensioner to hold the tensioner shaft in place.
 - ii) Ensure that the lock pin goes through the side of the tensioner and through the plunger and protrudes out on the other side.
 - iii) If you are able to do this you can loosen the tensioner bolts and let it drop to the bottom of its adjusting range.
 - iv) If the pin comes loose OR if you are not able to insert the lock pin then the resetting procedure for the tensioner must be followed according to factory procedures.
- 12) Resetting the cam belt tensioner
- a) With the tensioner removed from the engine it is necessary to compress the plunger into the tensioner body. *See Figures 10 & 11*
 - b) Place the tensioner into a vise and slowly compress the plunger.
 - i) **CAUTION:** Index the tensioner in the vise the same way it is installed in the engine. This is to ensure proper pin orientation when the tensioner is installed in the engine.
 - c) When the plunger is compressed into the tensioner body install the lock pin through the body and plunger to retain the plunger in place until the tensioner is installed.
- 13) Remove the cam belt from the camshaft drive pulleys and install the adjustable cam gears in their places.
NOTE: The DOHC engine has a staggered dowel pin arrangement. The intake cam alignment pin will be below the cam center bolt (6 o'clock position) while the exhaust cam alignment pin will be above the center bolt (12 o'clock position). The gears each have two pin slots in the center hub, which are used in different applications. Install the cam gears 180° out from each other with one gear facing up and one gear facing down. Ensure that the cams (and pins) are in their proper respective positions before you install the gears. **Check all the adjustment bolts on the pulleys to make sure that they are tight (15 ft-lbs) and that both gears are set to 0.** Install the center pulley bolts and snug them down.
- a) Set the camshafts in their proper position with the horizontal marks lined up.
 - b) Set the crankshaft at TDC for the number 1 cylinder.
 - c) Install the timing belt on all the gears and idler pulleys.
 - d) Apply 25 ft-lbs torque to the center nut of the tensioner pulley.
 - i) While the tension is being applied to the pulley, push the tensioner up against the tensioner pulley bracket and tighten the bolts.
 - ii) Check that the proper tension is being applied to the belt. This can be determined by feeling the resistance on the lock pin as you try to slide it in and out. The tension is right when you can slide the lock pin in and out of the tensioner easily.
 - iii) When tensioner is set remove the lock pin.
- 14) Check cam timing *See Figures 8 & 9*
- a) Rotate the crankshaft through three complete cycles and verify that the timing marks come back to the proper position. It is important that the marks come back to their original position. If they do not line up as before repeat the belt installation making sure that the marks are all lined up when the belt is installed.
 - b) On some vehicles there may be slight interference between the timing belt inspection cover's lower tabs and the tops of the cam adjustment bolts. If you experience this interference you can trim the ends of the bottom tabs of the timing belt inspection cover.
 - i) **NOTE:** Having a camshaft out of proper time will result in very poor performance and could also lead to serious engine damage.
 - c) Once cam timing is set you can proceed to re-install all the items removed for the installation of the adjustable cam gears. Follow the reverse order of the installation.

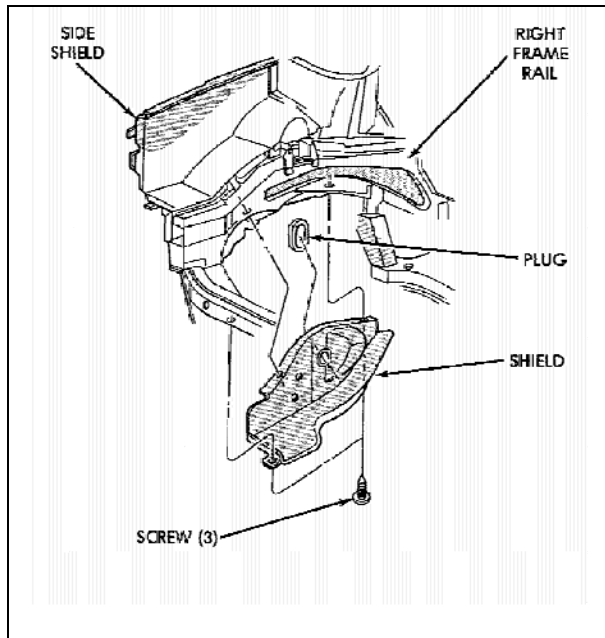

Fig 1 - Splash shield and access plug

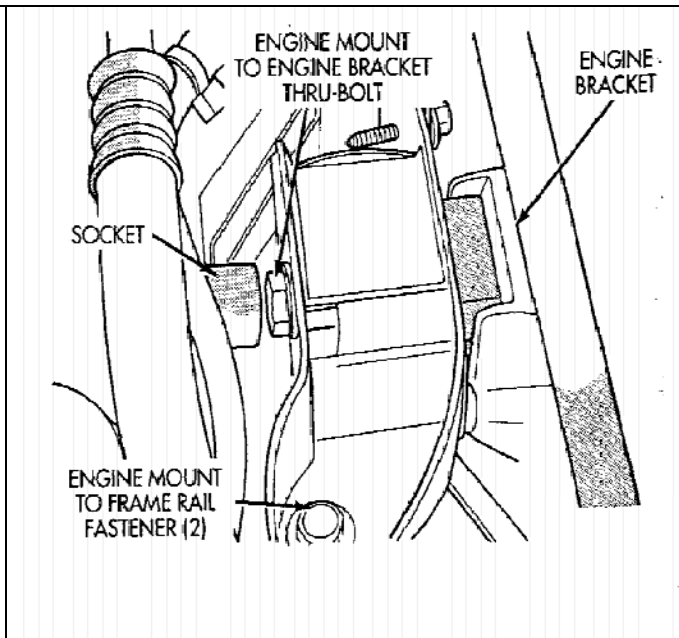

Fig 2 - Front engine mount

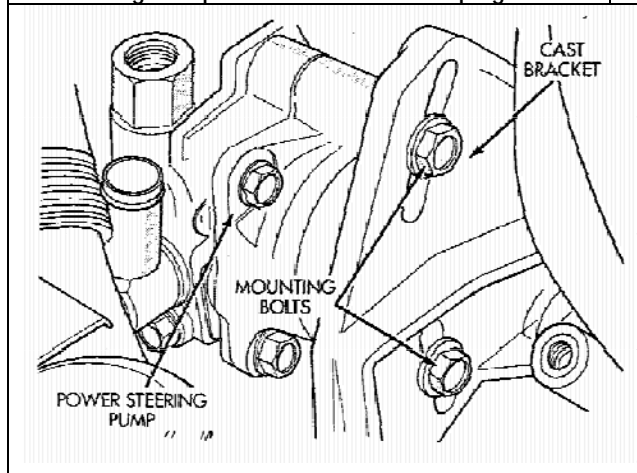

Fig 3 - PS rear mounting / adjusting bolts

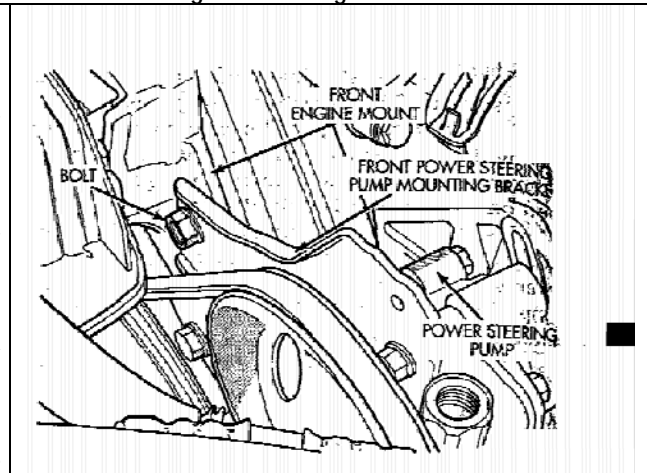

Fig 4 - PS front mounting bolt

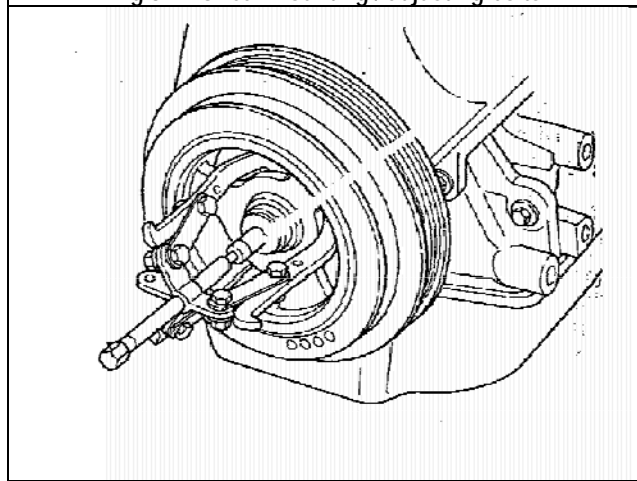

Fig 5 - Removal of crankshaft pulley

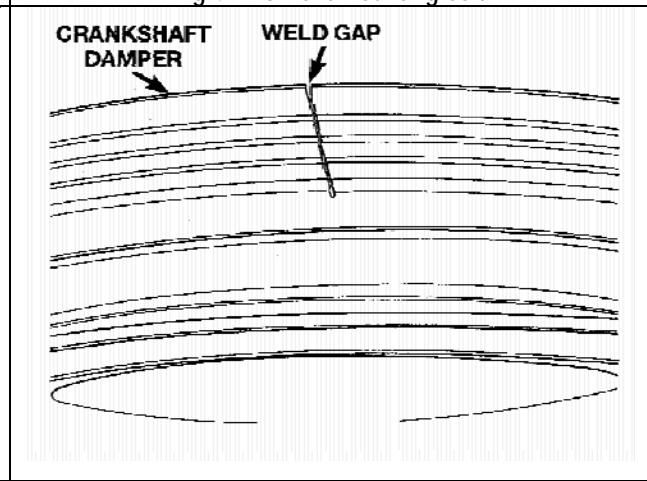

Fig 6 - Weld gap on crankshaft pulley

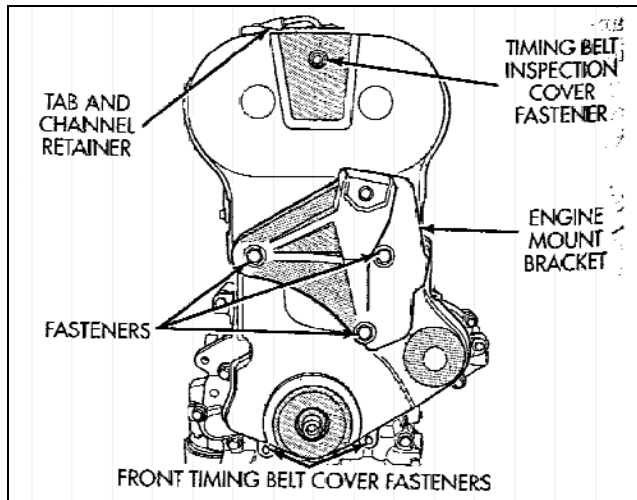

Fig 7 - Layout of front cover and bolts

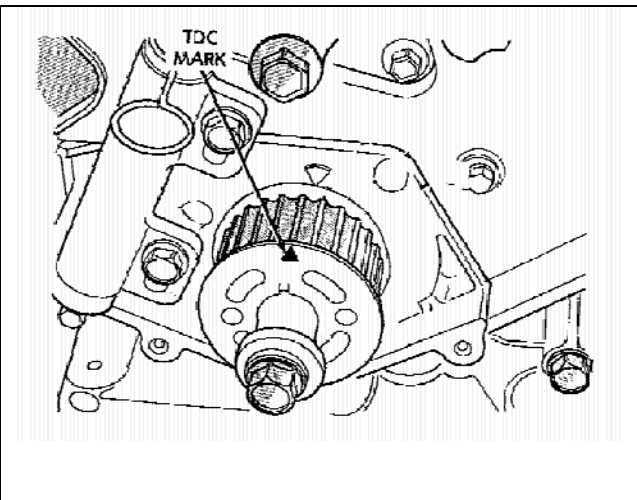

Fig 8 - Crankshaft front TDC mark

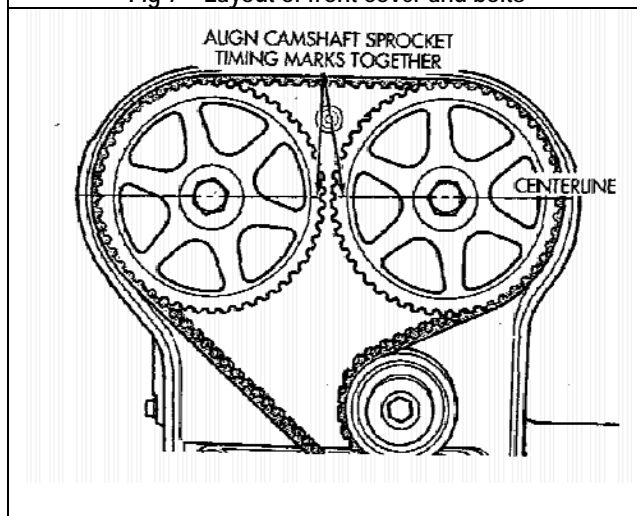

Fig 9 - Stock cam gear timing marks

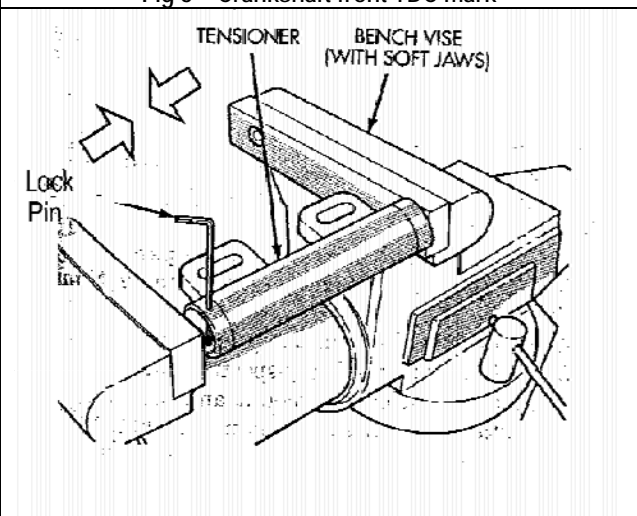
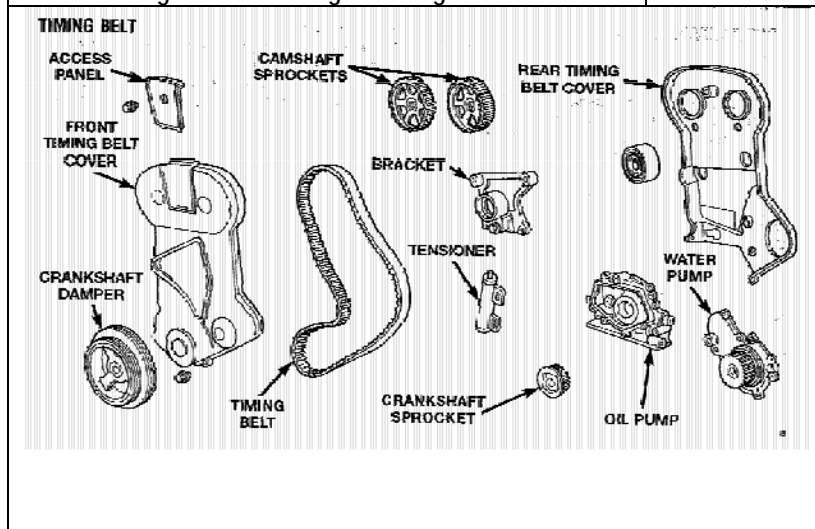

Fig 10 - Resetting belt tensioner



Timing Belt System

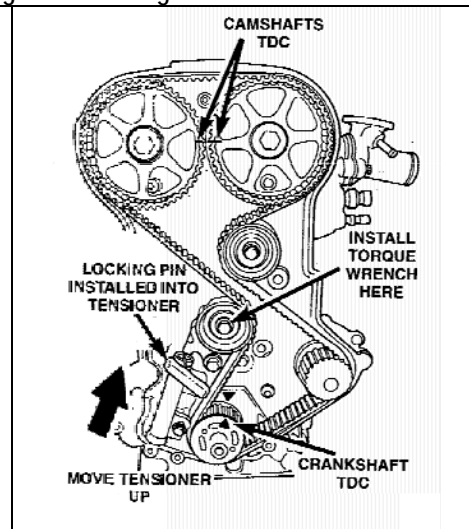

Fig 11 - Belt tension adjustment

For Technical Inquiries
Please E-mail us at
AEMtech@aempower.com