



Instruction Manual

P/N 30-4910 Wideband Ethanol Boost Gauge

P/N 30-4911 Wideband Ethanol Boost Gauge

WARNING:

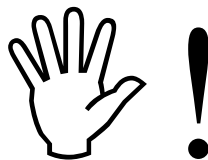

This installation is not for the electronic novice or the PC illiterate! Use this system with **EXTREME** caution! If you are not well versed in electronics and vehicle instrumentation or are not PC literate, please do not attempt the installation. Refer the installation to an AEM trained tuning shop. A list of AEM trained tuning shops is available at www.aemelectronics.com or by calling 800-423-0046. You should also visit the AEM Performance Electronics Forum at <http://www.aemelectronics.com>.

NOTE: AEM holds no responsibility for any engine damage that results from the misuse of this product!

This product is legal in California for racing vehicles only and should never be used on public highways.

Wideband Ethanol Boost Gauge Parts List

Qty	Description	Qty	Description
1	Wideband Ethanol Boost Gauge	1	Faceplate, Lambda Black
1	LSU4.2 UEGO Sensor	1	Faceplate, Vacuum Black
1	UEGO Harness	1	Harness, Input / Output
1	Install Kit w/ Bung	1	Rubber Band
1	Power/IO Harness	1	Wideband Ethanol Boost Instructions
1	USB Cable	1	Gauge Box
1	Faceplate, AFR White	1	Boost Hose Adapter
1	Faceplate, Boost Black	1	Vacuum Hose, 7/64" ID x 36" L
1	Faceplate, Boost White	1	Silver Bezel
1	Flex Fuel Sensor (30-4911 Only)	2	3/8" - SAE Barb Fittings (30-4911 Only)

GETTING STARTED

THIS PRODUCT DOES NOT INCLUDE SOFTWARE IN THE PACKAGING. PLEASE DOWNLOAD AND INSTALL THE WIDEBAND ETHANOL BOOST CONFIGURATION SOFTWARE FROM THE AEM WEBSITE AT: www.aemelectronics.com/downloads

Software Installation Instructions

Follow the Installation Instructions as outlined in the forum post described above. After the software installation is complete, double-click on the AEM Wideband Ethanol Boost icon (shown below) to launch the application.

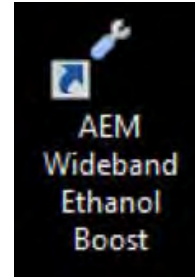

Connect the USB cable to the PC. The Wideband Ethanol Boost will turn ON with ignition key-on power. Alternatively, the Wideband Ethanol Boost can be bench-programmed outside of the vehicle without powering it by connecting just the USB cable. However, the UEGO sensor, MAP sensor, Flex Fuel sensor, analog outputs, and CAN outputs will not function.

Overview

AEM Wideband Ethanol Boost is an advanced safety device that allows the end user to closely monitor the performance of their engine. As a tuning tool, this device provides the ability to accurately monitor AFR, while actively protecting the engine by constantly recording AFR curves and activating a user-defined failsafe strategy if it runs dangerously lean or excessively rich.

The Wideband Ethanol Boost Gauge is a UEGO (Universal Exhaust Gas Oxygen) controller with an internal boost sensor, an internal data logger and a full color Organic Light Emitting Diode (OLED) display. It includes technology to activate a failsafe strategy in the event AFR falls outside of a user-defined operating window. If the AFR falls outside of the set operating window, the Wideband Ethanol Boost Gauge triggers a user defined output function that can save an engine from catastrophic damage.

This product allows the user to view and log the output of a flex fuel ethanol content sensor. P/N 30-4911 is supplied with an AEM Flex Fuel Sensor; however, 30-4900 is not. It is recommended to use one of the following AEM sensors:

Part Number	Description
30-2200	Ethanol Content Flex Fuel Sensor Kit (Barbed)
30-2201	Ethanol Content Flex Fuel Sensor Kit (-6 AN)

*Most "Continental" or "GM" style sensors are compatible with the 30-4910/4911 Wideband Ethanol Boost Gauge. Sensors that output a 12V square wave using the following calibration are compatible.

Description	Calibration	Conversion Formula
Ethanol Content (%)	50 Hertz = 0% ethanol 150 Hertz = 100% ethanol	ethanol % = [Frequency (Hz) - 50]
Fuel Temperature (degC)	1 millisecond pulsewidth = -40 degC 5 milliseconds pulsewidth = 125 degC	degC = [41.25 * Pulsewidth (ms)] - 81.25

ECU / Datalogger

Installation Diagram

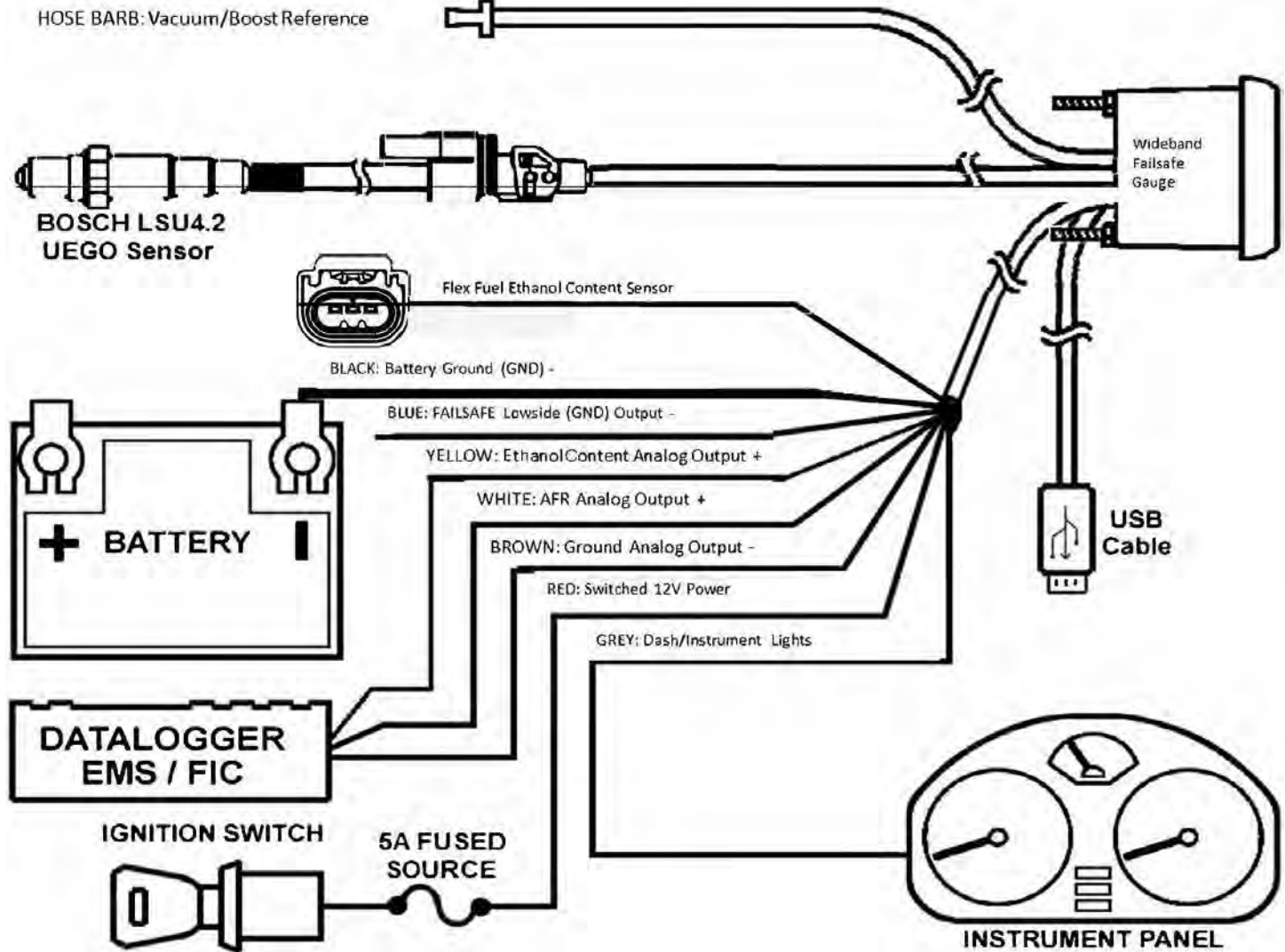

Installation

1. Disconnect the negative battery cable.
2. Temporarily install gauge without bracket into desired mounting location. Gauge mounts into a 2-1/16" (52MM) hole. The supplied rubber band can be used as a spacer around the gauge if it fits loosely in mounting hole.
3. Locate a suitable place in the exhaust system to install the included oxygen sensor weld bung. On non-turbocharged engines, mount the oxygen sensor in the exhaust system at least 18 inches downstream from the exhaust port. On turbocharged engines the oxygen sensor must be installed after the turbocharger, ideally 18" downstream from the turbocharger exhaust housing. NOTE: If the sensor is mounted before the turbocharger the pressure differential will affect the accuracy of the unit. For accurate readings, the sensor must be mounted upstream of the catalytic converters and/or auxiliary air pumps. To prevent collection of liquids between the sensor housing and sensor element during the cold start phase, the installation angle should be inclined at least 10° from horizontal with the electrical connection upwards, see image below.

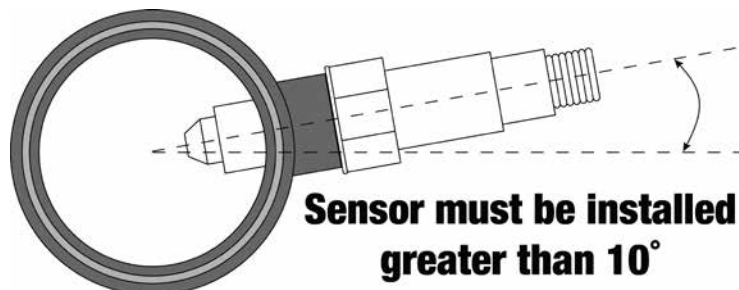

4. Next, the UEGO sensor 8-pin wiring harness should be routed to the oxygen sensor bung.

Pin	Color	Description
1	N/C	N/C
2	White	Heat -
3	Orange	VM
4	Green	IA
5	Red	IP
6	Black	UN
7	N/C	N/C
8	Brown	12V

WBFS 8-Pin Harness Connector (Wire Side)

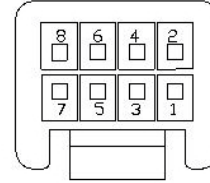

5. Next the main 16-pin connector will be manually wired into the vehicle.

Pin	Color	Description
1	Black	Ground; connect to good chassis ground or directly to battery negative (-) terminal
2	Red	Ignition power; connect to a fused key on +12V power source
3	Black	USB - Dedicated
4	N/C	Reserved
5	Red	USB - Dedicated
6	Green	USB - Dedicated
7	Blue	*OPTIONAL* Ground output; connect to an external auxiliary device (1.5A max current)
8	White	USB - Dedicated
9	Green	*OPTIONAL* Flex Fuel Ethanol Content Sensor Signal Input
10	Gray	*OPTIONAL* Gauge backlighting; connect to instrument lighting dimmer wire
11	N/C	Reserved
12	N/C**	*OPTIONAL* AEMnet -
13	N/C**	*OPTIONAL* AEMnet +
14	Brown	*OPTIONAL* Analog ground for AFR and MAP; connect to sensor ground of data logger or EMS
15	White	*OPTIONAL* 0-5V analog output for AFR; connect to + analog input of data logger or EMS
16	Yellow	*OPTIONAL* 0-5V analog output for Ethanol Content; connect to + analog input of data logger or EMS

WBFS 16-Pin Harness Connector (Wire Side)

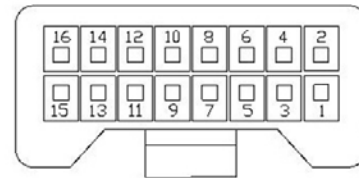

NOTES:

- Pins 14/15 are differential analog outputs. The brown wire should be connected to an analog ground input for best results. If the EMS, logger or similar device does not have an analog ground input, the brown wire should be connected to a sensor ground. If no sensor ground is available, the brown wire should be connected to a power ground. The brown wire **must** be connected in order to obtain correct AFR and MAP readings from the analog output(s).
- ** Pins 12/13 are un-populated as delivered. Please order the optional 30-3439 wiring harness to connect the WBFS gauge to other AEMnet products.

6. Connect the pre-terminated brown three pin connector to the flex fuel ethanol content sensor, if present.

Pin	Color	Description
1	Red	Vcc – Battery 12V
2	Black	GND – Battery Ground
3	Green	Vout – Sensor Output (10k pullup to pin 1)

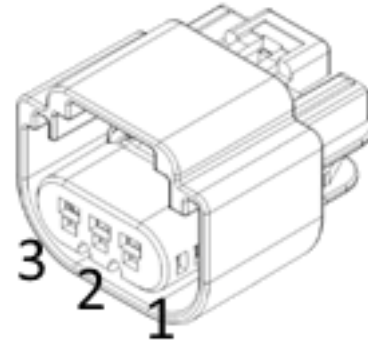

7. Connect all cables and wiring harnesses to gauge. Fully install gauge into hole using mounting bracket and nuts.
8. Install USB cable so the PC end of the cable is easily accessible and route the gauge end of cable to the gauge mounting location. USB cable is meant to be permanently installed to gauge and left in vehicle. Stow PC end of cable in location such as glove box or center console, etc.

Flex Fuel Ethanol Content Sensor Installation

The sensor must be installed in the fuel return line between the fuel pressure regulator and the fuel tank, reference the diagram below. The sensor may be installed in any orientation; the direction of flow through the sensor does not matter. It should be noted that the entirety of the fuel flow returning from the fuel rail is not required to travel through the sensor. This may be useful on very high flow systems with a larger than typical return line. In these cases, the sensor can be run in a smaller parallel circuit to measure just a portion of the return flow so that the sensor does not become a restriction for the entirety of the return fuel flow.

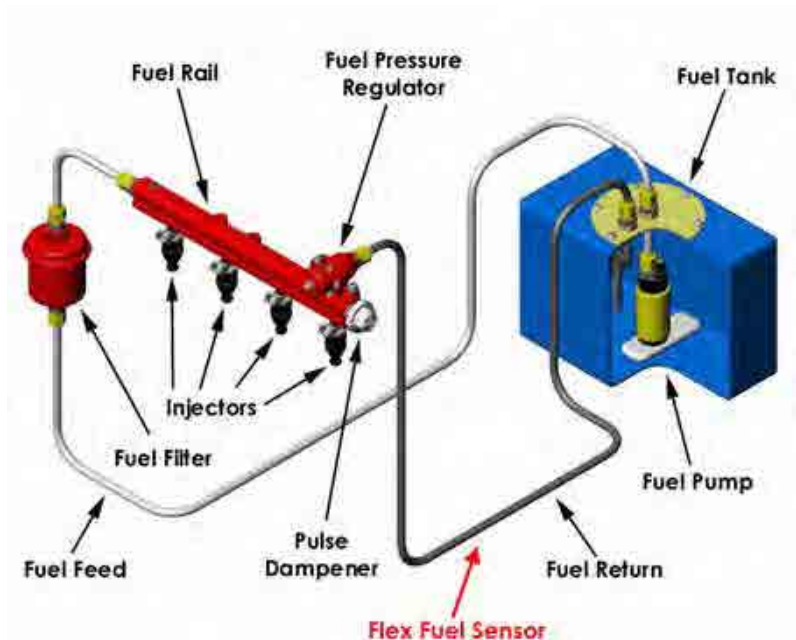

Please ensure that the barbed fittings are installed securely and verify the system is completely leak free before proceeding.



Wideband Ethanol Boost Configuration

In this tab, the AFR monitoring and alarm output functionality of the Wideband Ethanol Boost can be configured.



Air to Fuel Ratio vs. Pressure **Description**

Displays AFR vs. Pressure data points. AFR points will be populated live whenever the PC is connected to the Wideband Ethanol Boost and the UEGO sensor is registering an input. The current AFR and Pressure values are shown live on the right side of the graph. The graph area is where the high and low AFR limit lines are established. Configure the pressure scale and AFR scale before setting the boundary lines as they will reset each time a different scale is selected.

Graph

Button	Description
Auto Set Limits	Automatically sets the upper and lower AFR lines based on an average of the collected AFR data points
Reset Limits	Resets the upper AFR limit line to maximum and the lower AFR limit line to minimum
Clear Graph	Clears all the displayed AFR data points from the graph; does not clear stored AFR data from logger

Logger

Button	Description
Log Percentage	Displays current amount of data recorded
Download Log	Downloads all the collected AFR data that is stored in the logger; will prompt to save log to disk; log files saved as .daq for direct viewing in AEMdata program
Clear Log	Clears all stored AFR data from the logger

Flex Fuel Sensor

Parameter	Description
Ethanol (%)	Displays the current flex fuel sensor ethanol content percentage.
Fuel Temp (degC)	Displays the flex fuel sensor fuel temperature in degrees Celsius.

Alarm Configuration

Option	Description
Alarm Delay	Period of time that measured AFR can be outside the upper and lower AFR limit lines before an alarm condition is triggered; 100-1000 milliseconds
Alarm Reset	Period of time AFR must be within the acceptable range before the alarm will automatically reset and turn OFF; 1-10 seconds
Disable Auto Reset	Select to require power cycle to reset alarm; overrides the automatic alarm reset period.
GND Output	Select to turn the ground output ON or turn the ground output OFF when an alarm is triggered; 1.5 amps max

Alarm Status

Parameter	Description
Status Indicator	Color indicates status; green is system ready, red is alarm triggered
Source	Indicates the source of the alarm condition; possible alarm conditions are high AFR, low AFR, auxiliary input, and alarm test
Alarm Press	Pressure when alarm was triggered; Units determined by Pressure Scale selection
Alarm AFR	AFR when alarm was triggered; Units determined by AFR Scale selection
Option	Description
Alarm Test	Simulates the alarm to test output configuration; test duration set by Alarm Delay value

Gauge Configuration

In this tab, the gauge lighting and display features can be configured.



Display Option

Option	Description
Upper Display	Upper display reading configuration; use to select either pressure (InHg / PSig or Bar) or O2 sensor (AFR or Lambda)
Lower Display	Lower Display reading configuration; use to select either flex fuel ethanol content percentage or off. If off then only the upper display reading will be visible.
Installed Faceplate	Faceplate configuration; use to match 24 outer LEDs to faceplate with either Pressure (InHg / PSig or Bar) or O2 sensor (AFR or Lambda) [See Appendix II – <i>Changing Faceplate / Bezel</i>]

Alarm Flash

Option	Description
Flash Speed	Select speed of flashing while alarm is triggered; flash slow or fast

Dimmer Max Brightness

Option	Description
Dimmer Max Brightness	Select whether +12V or ground indicates maximum backlighting brightness

Bar-Graph LED Color

Option	Description
RED LED (1)	Can be disabled; use slider to configure multiple LEDs. Reference gauge display at bottom right.
ORG LED (2)	Can be disabled; use slider to configure multiple LEDs. Reference gauge display at bottom right.
GRN LED (3)	Cannot be disabled; use slider to configure multiple LEDs. Reference gauge display at bottom right.
ORG LED (4)	Can be disabled; use slider to configure multiple LEDs. Reference gauge display at bottom right.
RED LED (5)	Can be disabled; use slider to configure multiple LEDs. Reference gauge display at bottom right.

Wideband Ethanol Boost Failsafe Tuning

The following is a basic guideline strategy for configuring the Wideband Failsafe for the first time. The ideal time to configure the Wideband Ethanol Boost is while the vehicle is being dyno tuned. **Ensure your engine is fully functional mechanically before starting to configure the Wideband Failsafe!**

1. In the Wideband Ethanol Boost Configuration tab, click Clear Graph and Reset Limits to zero all settings.
2. If a boosted pressure scale is selected, there will be a pink triangular cursor on the left side of the graph when the engine is in high vacuum, as shown below. The upper and lower limits for this high vacuum area will use the lowest pressure (furthest left) breakpoint for alarm triggering.



3. Run the engine as you would normally drive the vehicle then complete a series of long sweeping high load 3rd and 4th gear pulls going from low to high RPM each time to populate the graph with AFR data. Avoid making quick hard pulls as this may skew the AFR data points. Repeat this procedure until a baseline AFR curve is established. Note: You may notice that a few random AFR data points are plotted well outside of the normal AFR curve. This is caused by dynamic tip-in wall wetting in transient pressure situations. This is normal behavior and false triggers can be ignored in the configuration setup process below.



4. With a baseline AFR curve now established, click on Auto Set Limits and the software will produce its best suggested high and low AFR limit lines based on the populated AFR data shown on the graph. Review and adjust the high and low AFR limit lines as needed to contour the lines around the baseline AFR curve (shown below). This can be done by clicking on a breakpoint and either dragging up or down with the mouse or by clicking the up and down arrows on the keyboard. To move to the next breakpoint, click on it with the mouse or use the right and left arrows. Pressing the Tab key will toggle back and forth between the high and low limit lines.

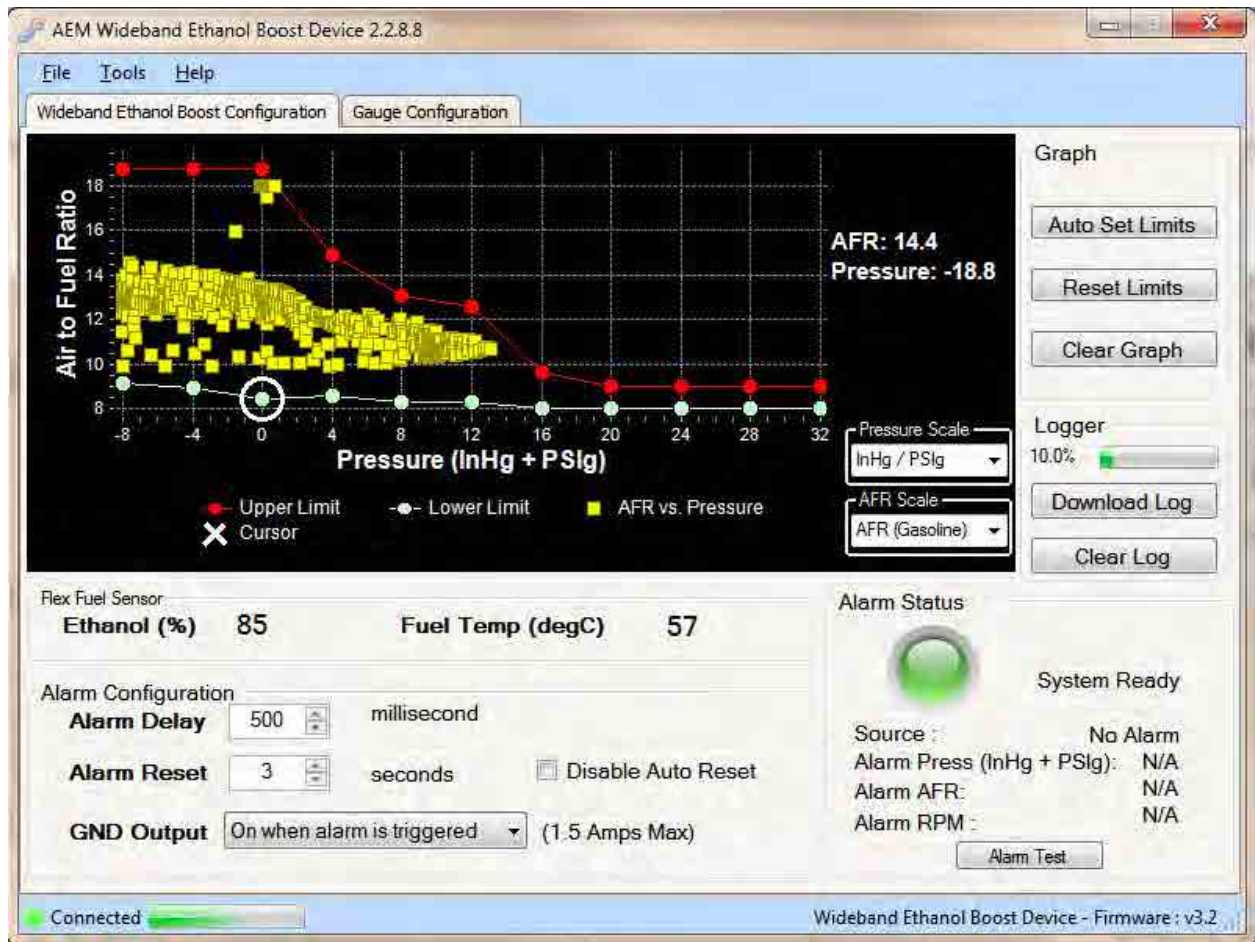

5. Test the configuration using your anticipated normal operating conditions with varying engine speed and engine load situations to account for starting, stopping, accelerating, high boost, low boost, tip in, fast shifts, slow shifts, etc. If false triggers occur, either adjust the high or low AFR curve up or down at the pressure breakpoint where the alarm occurred or adjust the Alarm Delay setting.

NOTE: There are two general configuration strategies to follow when using the Wideband Ethanol Boost. The high and low AFR limit lines can be set very tightly to the baseline AFR curve and a longer Alarm Delay can be used. Conversely, the high and low AFR limit lines can be set further way from the baseline AFR curve and a shorter Alarm Delay can be used. Furthermore, many tuners may conclude that a rich AFR is more acceptable for, safety measures, than a lean AFR. If true, a looser tolerance can be put into the lower limit line as depicted in the graph above. Only thorough configuration testing will reveal which strategy is best for your application.

Data Logger

The Wideband Ethanol Boost has an internal logger that can store approximately 2.5 hours of data. The system maintains two levels of data logs. First, all AFR data points are stored and downloadable for viewing on the AFR vs. Pressure Graph in the Wideband Ethanol Boost Configuration tab. Second, all inputs, outputs, and alarm triggers are logged in special log file format for viewing with the AEMdata software that comes as part of the Wideband Failsafe download package. Once the logger memory has filled up, the logger will begin to loop log and the oldest data will be discarded as new data is collected (data points that were collected will slowly start disappearing). The following is a basic guideline on how to use the internal data logger. NOTE: The internal data logger is always running when 12V is present.

1. Connect USB cable to PC.
2. In the Wideband Ethanol Boost Configuration tab under Logger, click Download Log. All logged AFR data points will now be displayed in the AFR vs. Pressure Graph.
3. To download the log to the PC, click YES when prompted to save data to disc and then save log in desired location.
4. Click YES when prompted to open file in AEMdata, the saved data log will now open as shown below.

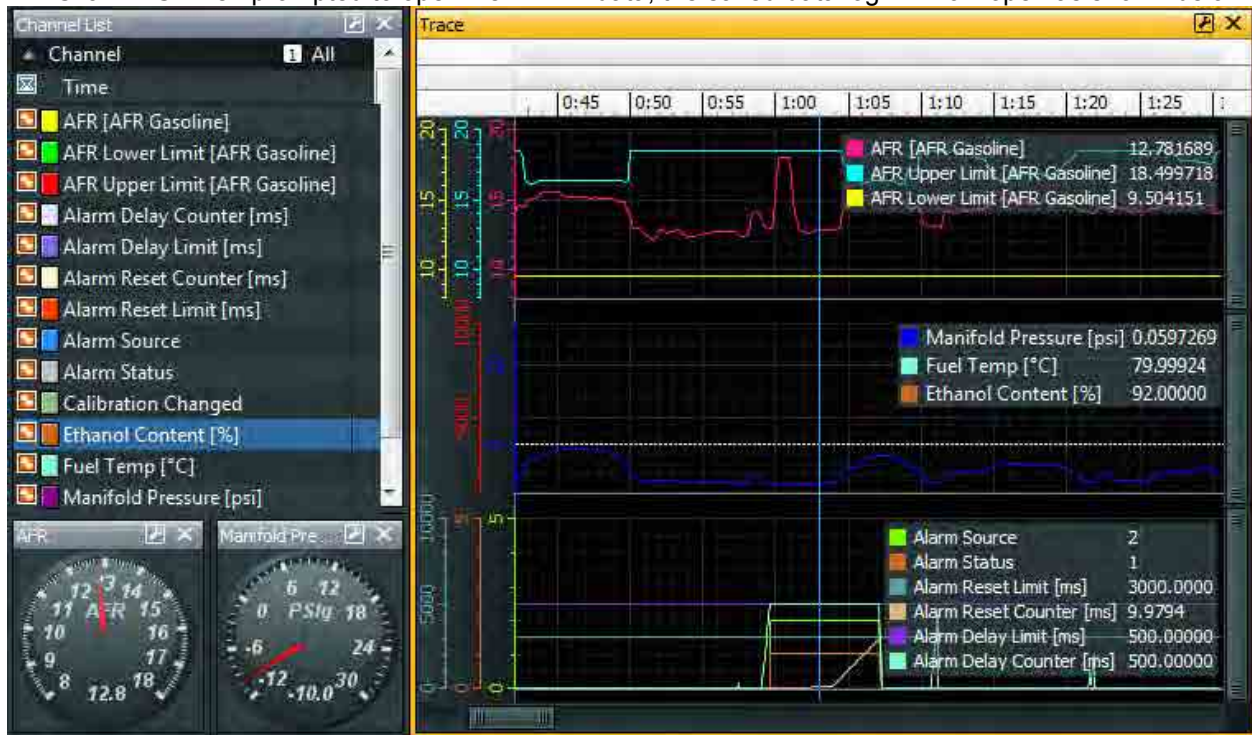

Plot One

Parameter	Description
AFR	Current measured AFR (Gasoline)
AFR Upper Limit	Current upper AFR limit value as set from the Wideband Ethanol Boost Configuration tab
AFR Lower Limit	Current lower AFR limit value as set from the Wideband Ethanol Boost Configuration tab

Plot Two

Parameter	Description
Manifold Pressure	Current measured Manifold Pressure in PSiG
Engine Speed	Current measured RPM, if connected and used

Plot Three

Parameter	Description
Alarm Source	Indicates what triggered the alarm condition; 3-low AFR condition, 5-high AFR condition, 3-auxiliary input, 9-alarm test
Alarm Status	Indicates state of alarm; 1-alarm triggered, 0-alarm not triggered
Alarm Reset Limit	Alarm Reset value
Alarm Reset Counter	Counts up from zero to Alarm Reset value once AFR has returned into the acceptable range
Alarm Delay Limit	Alarm Delay value
Alarm Delay Counter	Counts up from zero to Alarm Delay value when AFR occurs outside the high or low AFR limits; once full Alarm Delay value is reached the alarm will trigger; counter will reset back to zero if AFR returns back into

the acceptable range once count up has began

Output Configuration

The Wideband Ethanol Boost has one ground (low side) output that is triggered when an alarm condition exists. This output can be used in a multitude of ways to reduce boost, retard ignition timing, or otherwise protect an engine in the event there is a problem with the fuel system. The following is an index of possible auxiliary devices that can be triggered by the alarm output:

AEM EMS

Function	Description
Nitrous Fuel & Ignition Maps	Use the ground output to trigger the nitrous fuel and ignition maps; ignition timing can be reduced and fuel can be added
Boost Switch	Use the ground output to trigger the boost switch; a lower boost value can be targeted
Two-Step	Use the ground output to trigger the two-step; a lower engine rev limit can be selected

MSD Ignition Products

Product	Description
DIS2 (62112)	Brown wire: use a relay to apply +12V to trigger ignition interrupt Blue wire: use a relay to apply +12V to trigger two step Pink wire: use a relay to apply +12V to trigger timing retard
DIS4 (62152)	Brown wire: use a relay to apply +12V to trigger ignition interrupt Blue wire: use a relay to apply +12V to trigger two step Pink wire: use a relay to apply +12V to trigger timing retard
6AL-2 (6421)	Blue wire: use a relay to apply +12V to trigger two step
Programmable 6AL-2 (6530)	Dark blue wire: use a relay to apply +12V to trigger launch rev limit Light blue wire: use a relay to apply +12V to trigger burn out rev limit Pink wire: use a relay to apply +12V to trigger timing retard
Digital 6 Plus (6520)	Blue wire: use a relay to apply +12V to trigger two step Pink wire: use a relay to apply +12V to trigger timing retard
Start/Retard Control (8982)	Violet wire: use a relay to apply +12V to trigger timing retard
Timing Controller (8980)	Grey wire: ground input to trigger timing retard

Warning Light

The Wideband Ethanol Boost can also be used to directly activate a warning light (Autometer PN 3239 or similar). Connect the warning light's white wire to 12V and the low side output to the warning light's black (ground) wire to turn the light ON. NOTE: High current lights will require a relay to be installed.

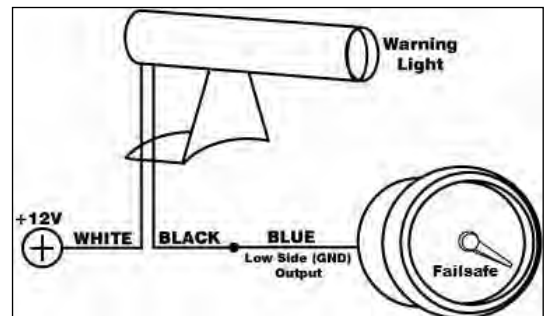

NC/NO Relay

The following are examples of how a NC/NO relay (Bosch PN 0-332-019-203 or similar) can be configured for use with the Wideband Failsafe.

Signal Interrupt: The low side (ground) output from the Wideband Ethanol Boost can be used to turn ON a NC (normally closed) relay and interrupt the output signal from a boost controller to its boost solenoid (shown below). NOTE: Be sure that pulling power from the boost solenoid will decrease boost down to the wastegate spring pressure rather than increase boost to the turbochargers max. This will depend on what type of wastegate is used and how it is plumbed with vacuum hose.

Auxiliary Device: The low side (ground) output from the Wideband Ethanol Boost can be used to turn ON a NO (normally open) relay and activate or deactivate an auxiliary device that can be used to reduce timing or boost or control some other function when the current requirement is greater than 1.5 amps.

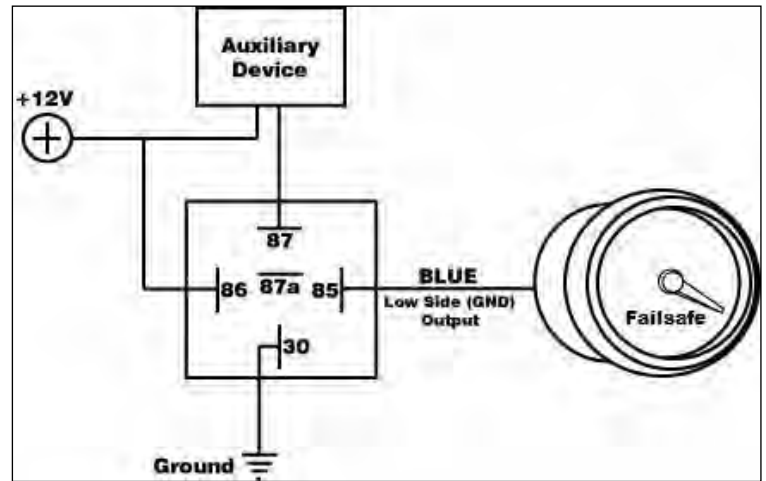
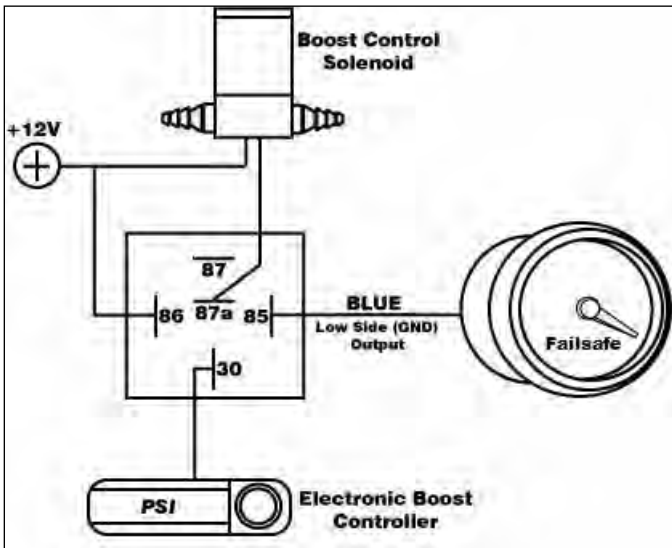

Appendix I - Analog Outputs

There are 2 analog outputs from the Wideband Ethanol Boost; Ethanol Content (Flex Fuel %) and AFR (O2). These outputs are both linear DC voltage signals that vary with Ethanol Content or AFR. These signals are used for sending information to a data logger or an engine management system such as an AEM EMS, AEM F/IC, AEM Infinity, etc.

% = (Volts *25) - 12.5	
Voltage	Ethanol %
0.5	0
1.0	12.5
1.5	25.0
2.0	37.5
2.5	50.0
3.0	62.5
3.5	75.0
4.0	87.5
4.5	100
5.0	SENSOR ERROR

AFR Output Transfer Function		
AFR (Gas) = (2.375 * Volts) + 7.3125		
Voltage	AFR (Gas)	AFR (Lambda)
0.5	8.50	0.58
1.0	9.69	0.66
1.5	10.88	0.74
2.0	12.06	0.82
2.5	13.25	0.91
3.0	14.44	0.99
3.5	15.63	1.07
4.0	16.81	1.15
4.5	18.00	1.23

Appendix II - Changing Faceplate / Bezel

The Wideband Ethanol Boost gauge comes with the black bezel and Air/Fuel-Gasoline faceplate installed. However, a silver bezel and multiple faceplates are also included. To change them, orient the gauge so you are looking at the faceplate. Rotate the bezel counter-clockwise to unscrew it from the gauge cup. The bezel, lens, and rubber spacer are all removable. Next, remove the faceplate, but note the two keyways on each side. When inserting the new faceplate be cognizant of these keyways and line them up before reassembling.

When reassembling the gauge, it may be necessary to apply a light amount of pressure on the lens and spacer to keep the faceplate from rotating when reinstalling the bezel. **Do not over-tighten the bezel when reassembling the gauge.**

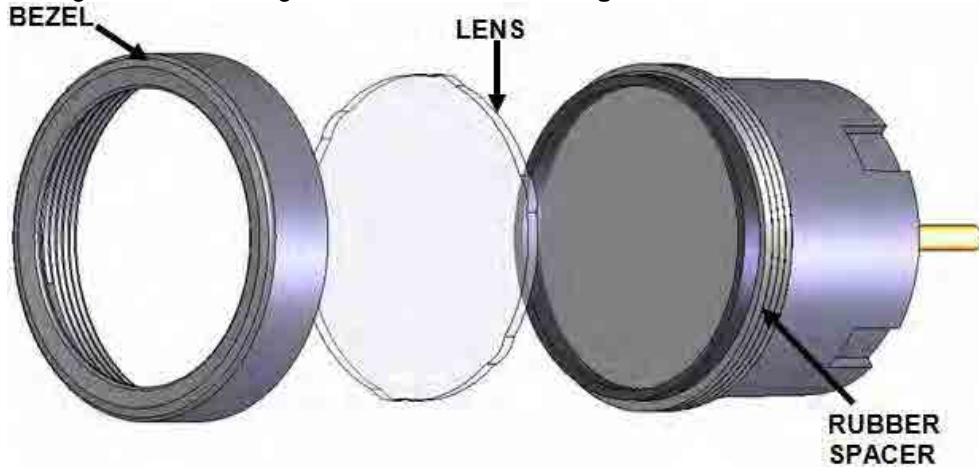

Appendix III - AEMnet

The following instructions describe the proper installation of the optional AEMnet Harness (30-3439), which is used to connect the Wideband Ethanol Boost AEMnet communication lines to a second (or multiple) AEMnet device(s).

Disconnect the Wideband Ethanol Boost 16-pin harness connector from the Wideband Failsafe gauge. The harness connector has a latch on the bottom side that needs to be squeezed as the connector is lightly freed from the gauge.



Locate the green and white pre-crimped terminals on the end of the AEMnet Harness. This table shows the Wideband Ethanol Boost connector and pinout including the green and white leads from the AEMnet harness.

PIN	WIRE COLOR	FUNCTION	TERMINAL TYPE
1	BLACK		
2	RED		
3	BLACK		
4	N/A		
5	RED		
6	GREEN		
7	BLUE		
8	WHITE		
9	GREEN		
10	GRAY		
11	N/A		
12	GREEN	AEMnet -	SPUD-001T-P0.5
13	WHITE	AEMnet +	SPUD-001T-P0.5
14	BROWN		
15	WHITE		
16	YELLOW		

WBFS 16-Pin Harness Connector <Wire Side>

Before inserting the terminals into the connector, refer to the figure to be sure that the locking mechanism on the terminals is positioned properly in the connector.

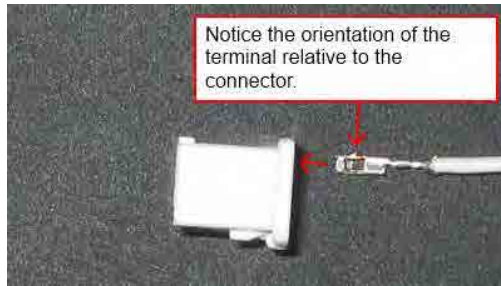

Insert the AEMnet+ terminal (white wire) into the available Pin 13 on the Wideband Ethanol Boost connector. Push the wire in until the locking mechanism on the terminal and connector lock into place. Pull lightly on the white wire to confirm the locking mechanism has latched. This figure shows the correct placement of the AEMnet+ terminal.



Insert the AEMnet- terminal (green wire) into the available Pin 12 on the Wideband Ethanol Boost connector. Push the wire in until the locking mechanism on the terminal and connector lock into place. Pull lightly on the green wire to confirm the locking mechanism has latched. This figure shows the correct placement of the AEMnet- terminal.



Connect the Deutsch connector on the opposite end of the AEMnet harness to a mating Deutsch connector on a second device with AEMnet capabilities. The AEMnet harness includes a male and female Deutsch connector, allowing AEMnet devices to be daisy-chained together.

Appendix IV – Firmware Updates

Do not attempt to update firmware unless instructed by AEM Technical Support. To update the firmware, download the firmware file, if available, from www.aemelectronics.com/downloads. While connected to the gauge with the USB cable, open the AEM Wideband Ethanol Boost Software. Go to the Tools drop down menu and select Update Firmware and follow the on-screen instructions.

Appendix V – AEMnet Messages

Message 0x00000026 (29-bit)
Rate: 10mS continuous

Byte	Label	Data Type	Scaling	Offset	Range
0	Lambda	16 bit unsigned	.0001 Lambda/bit	0	0 to 6.5535 Lambda
1					
2	Pressure	16 bit unsigned	.001 PSI/bit	-15	-15 to 50.535 PSI
3					
4	Fuel Temperature	8 bit signed	1 degC/bit	0	-40 degC – 125degC
5	Flex Fuel Ethanol Content	8 bit unsigned	1 %/bit	0	0 – 100%
6 (bit0)	AFR Ready	Boolean	0 = false, 1 = true	0	0/1
6 (bit1)	AFR Heater Open Error	Boolean	0 = false, 1 = true	0	0/1
6 (bit2)	AFR CJ125 Error	Boolean	0 = false, 1 = true	0	0/1
6 (bit3)	AFR Sensor Heating Up	Boolean	0 = false, 1 = true	0	0/1
6 (bit4)	AFR Low Voltage	Boolean	0 = false, 1 = true	0	0/1
6 (bit5)	AFR Heater Time-Out Error	Boolean	0 = false, 1 = true	0	0/1
6 (bit6)	AFR Heater Short Error	Boolean	0 = false, 1 = true	0	0/1
6 (bit7)	AFR Overtemp Error	Boolean	0 = false, 1 = true	0	0/1
7 (bit0)	Alarm Status	Boolean	0 = false, 1 = true	0	0/1
7 (bit1)	Alarm Source	Boolean	0 = false, 1 = true	0	0/1
7 (bit2)	Alarm Source	Boolean	0 = false, 1 = true	0	0/1
7 (bit3)	Alarm Source	Boolean	0 = false, 1 = true	0	0/1
7 (bit4)	---	---	---	---	---
7 (bit5)	---	---	---	---	---
7 (bit6)	---	---	---	---	---
7 (bit7)	---	---	---	---	---

Message 0x00000027 (29-bit)
Rate: 10mS continuous

Byte	Label	Data Type	Scaling	Offset	Range
0	Lambda Upper Limit	16 bit unsigned	.0001 Lambda/bit	0	0 to 6.5535 Lambda
1					
2	Lambda Lower Limit	16 bit unsigned	.0001 Lambda/bit	0	0 to 6.5535 Lambda
3					
4	Alarm Delay Limit	16 bit unsigned	1 mS/bit	0	0 to 65,535 mS
5					
6	Alarm Delay Counter	16 bit unsigned	1 mS/bit	0	0 to 65,535 mS
7					

Message 0x00000028 (29-bit)
Rate: 10mS while in alarm mode, not transmitted otherwise

Byte	Label	Data Type	Scaling	Offset	Range
0	Alarm Lambda	16 bit unsigned	.0001 Lambda/bit	0	0 to 6.5535 Lambda
1					
2	Alarm Pressure	16 bit unsigned	.001 PSI/bit	-15	-15 to 50.535 PSI
3					
4	Alarm Reset Limit	16 bit unsigned	1 mS/bit	0	0 to 65,535 mS
5					
6	Alarm Reset Counter	16 bit unsigned	1 mS/bit	0	0 to 65,535 mS
7					

12 Month Limited Warranty

Advanced Engine Management Inc. warrants to the consumer that all AEM High Performance products will be free from defects in material and workmanship for a period of twelve (12) months from date of the original purchase. Products that fail within this 12-month warranty period will be repaired or replaced at AEM's option, when determined by AEM that the product failed due to defects in material or workmanship. This warranty is limited to the repair or replacement of the AEM part. In no event shall this warranty exceed the original purchase price of the AEM part nor shall AEM be responsible for special, incidental or consequential damages or cost incurred due to the failure of this product. Warranty claims to AEM must be transportation prepaid and accompanied with dated proof of purchase. This warranty applies only to the original purchaser of product and is non-transferable. All implied warranties shall be limited in duration to the said 12-month warranty period. Improper use or installation, accident, abuse, unauthorized repairs or alterations voids this warranty. AEM disclaims any liability for consequential damages due to breach of any written or implied warranty on all products manufactured by AEM. Warranty returns will only be accepted by AEM when accompanied by a valid Return Merchandise Authorization (RMA) number. Product must be received by AEM within 30 days of the date the RMA is issued.

UEGO oxygen sensors are considered wear items and are not covered under warranty.

Please note that before AEM can issue an RMA for any electronic product, it is first necessary for the installer or end user to contact the EMS tech line at 1-800-423-0046 to discuss the problem. Most issues can be resolved over the phone. Under no circumstances should a system be returned or a RMA requested before the above process transpires.

AEM will not be responsible for electronic products that are installed incorrectly, installed in a non-approved application, misused, or tampered with.

Any AEM electronics product can be returned for repair if it is out of the warranty period. There is a minimum charge of \$50.00 for inspection and diagnosis of AEM electronic parts. Parts used in the repair of AEM electronic components will be extra. AEM will provide an estimate of repairs and receive written or electronic authorization before repairs are made to the product.

Need additional help? Contact the AEM Performance Electronics tech department at 1-800-423-0046 or tech@aempower.com, or visit the AEM Performance Electronics forum at: <http://aemelectronics.com/forum/>